

$$\mathbf{V} = \mathbf{ZI}$$

$$\sum \mathbf{I}_k = 0 \quad (\text{KCL})$$

$$\sum \mathbf{V}_k = 0 \quad (\text{KVL})$$

7. The techniques of voltage/current division, series/parallel combination of impedance/admittance, circuit reduction, and Y - Δ transformation all apply to ac circuit analysis.
8. AC circuits are applied in phase-shifters and bridges.

REVIEW QUESTIONS

- 9.1** Which of the following is *not* a right way to express the sinusoid $A \cos \omega t$?
 (a) $A \cos 2\pi ft$ (b) $A \cos(2\pi t/T)$
 (c) $A \cos \omega(t - T)$ (d) $A \sin(\omega t - 90^\circ)$
- 9.2** A function that repeats itself after fixed intervals is said to be:
 (a) a phasor (b) harmonic
 (c) periodic (d) reactive
- 9.3** Which of these frequencies has the shorter period?
 (a) 1 krad/s (b) 1 kHz
- 9.4** If $v_1 = 30 \sin(\omega t + 10^\circ)$ and $v_2 = 20 \sin(\omega t + 50^\circ)$, which of these statements are true?
 (a) v_1 leads v_2 (b) v_2 leads v_1
 (c) v_2 lags v_1 (d) v_1 lags v_2
 (e) v_1 and v_2 are in phase
- 9.5** The voltage across an inductor leads the current through it by 90° .
 (a) True (b) False
- 9.6** The imaginary part of impedance is called:
 (a) resistance (b) admittance
 (c) susceptance (d) conductance
 (e) reactance
- 9.7** The impedance of a capacitor increases with increasing frequency.
 (a) True (b) False

- 9.8** At what frequency will the output voltage $v_o(t)$ in Fig. 9.39 be equal to the input voltage $v(t)$?
 (a) 0 rad/s (b) 1 rad/s (c) 4 rad/s
 (d) ∞ rad/s (e) none of the above

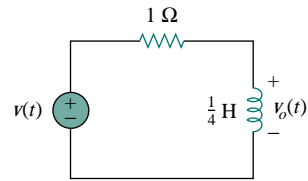

Figure 9.39 For Review Question 9.8.

- 9.9** A series RC circuit has $V_R = 12$ V and $V_C = 5$ V. The supply voltage is:
 (a) -7 V (b) 7 V (c) 13 V (d) 17 V
- 9.10** A series RCL circuit has $R = 30 \Omega$, $X_C = -50 \Omega$, and $X_L = 90 \Omega$. The impedance of the circuit is:
 (a) $30 + j140 \Omega$ (b) $30 + j40 \Omega$
 (c) $30 - j40 \Omega$ (d) $-30 - j40 \Omega$
 (e) $-30 + j40 \Omega$

Answers: 9.1d, 9.2c, 9.3b, 9.4b,d, 9.5a, 9.6e, 9.7b, 9.8d, 9.9c, 9.10b.

PROBLEMS

Section 9.2 Sinusoids

- 9.1** In a linear circuit, the voltage source is

$$v_s = 12 \sin(10^3 t + 24^\circ) \text{ V}$$

- (a) What is the angular frequency of the voltage?
 (b) What is the frequency of the source?
 (c) Find the period of the voltage.

- (d) Express v_s in cosine form.
 (e) Determine v_s at $t = 2.5$ ms.

- 9.2** A current source in a linear circuit has

$$i_s = 8 \cos(500\pi t - 25^\circ) \text{ A}$$

- (a) What is the amplitude of the current?
 (b) What is the angular frequency?

- (c) Find the frequency of the current.
 (d) Calculate i_s at $t = 2$ ms.

9.3 Express the following functions in cosine form:

- (a) $4 \sin(\omega t - 30^\circ)$ (b) $-2 \sin 6t$
 (c) $-10 \sin(\omega t + 20^\circ)$

9.4 (a) Express $v = 8 \cos(7t + 15^\circ)$ in sine form.
 (b) Convert $i = -10 \sin(3t - 85^\circ)$ to cosine form.

9.5 Given $v_1 = 20 \sin(\omega t + 60^\circ)$ and $v_2 = 60 \cos(\omega t - 10^\circ)$, determine the phase angle between the two sinusoids and which one lags the other.

9.6 For the following pairs of sinusoids, determine which one leads and by how much.

- (a) $v(t) = 10 \cos(4t - 60^\circ)$ and $i(t) = 4 \sin(4t + 50^\circ)$
 (b) $v_1(t) = 4 \cos(377t + 10^\circ)$ and $v_2(t) = -20 \cos 377t$
 (c) $x(t) = 13 \cos 2t + 5 \sin 2t$ and $y(t) = 15 \cos(2t - 11.8^\circ)$

Section 9.3 Phasors

9.7 If $f(\phi) = \cos \phi + j \sin \phi$, show that $f(\phi) = e^{j\phi}$.

9.8 Calculate these complex numbers and express your results in rectangular form:

(a) $\frac{15 \angle 45^\circ}{3 - j4} + j2$

(b) $\frac{8 \angle -20^\circ}{(2 + j)(3 - j4)} + \frac{10}{-5 + j12}$

(c) $10 + (8 \angle 50^\circ)(5 - j12)$

9.9 Evaluate the following complex numbers and express your results in rectangular form:

(a) $2 + \frac{3 + j4}{5 - j8}$ (b) $4 \angle -10^\circ + \frac{1 - j2}{3 \angle 6^\circ}$

(c) $\frac{8 \angle 10^\circ + 6 \angle -20^\circ}{9 \angle 80^\circ - 4 \angle 50^\circ}$

9.10 Given the complex numbers $z_1 = -3 + j4$ and $z_2 = 12 + j5$, find:

(a) $z_1 z_2$ (b) $\frac{z_1}{z_2}$ (c) $\frac{z_1 + z_2}{z_1 - z_2}$

9.11 Let $\mathbf{X} = 8 \angle 40^\circ$ and $\mathbf{Y} = 10 \angle -30^\circ$. Evaluate the following quantities and express your results in polar form.

(a) $(\mathbf{X} + \mathbf{Y})\mathbf{X}^*$ (b) $(\mathbf{X} - \mathbf{Y})^*$ (c) $(\mathbf{X} + \mathbf{Y})/\mathbf{X}$

9.12 Evaluate these determinants:

(a) $\begin{vmatrix} 10 + j6 & 2 - j3 \\ -5 & -1 + j \end{vmatrix}$

(b) $\begin{vmatrix} 20 \angle -30^\circ & -4 \angle -10^\circ \\ 16 \angle 0^\circ & 3 \angle 45^\circ \end{vmatrix}$

(c) $\begin{vmatrix} 1 - j & -j & 0 \\ j & 1 & -j \\ 1 & j & 1 + j \end{vmatrix}$

9.13 Transform the following sinusoids to phasors:

- (a) $-10 \cos(4t + 75^\circ)$ (b) $5 \sin(20t - 10^\circ)$
 (c) $4 \cos 2t + 3 \sin 2t$

9.14 Express the sum of the following sinusoidal signals in the form of $A \cos(\omega t + \theta)$ with $A > 0$ and $0 < \theta < 360^\circ$.

- (a) $8 \cos(5t - 30^\circ) + 6 \cos 5t$
 (b) $20 \cos(120\pi t + 45^\circ) - 30 \sin(120\pi t + 20^\circ)$
 (c) $4 \sin 8t + 3 \sin(8t - 10^\circ)$

9.15 Obtain the sinusoids corresponding to each of the following phasors:

- (a) $\mathbf{V}_1 = 60 \angle 15^\circ$, $\omega = 1$
 (b) $\mathbf{V}_2 = 6 + j8$, $\omega = 40$
 (c) $\mathbf{I}_1 = 2.8e^{-j\pi/3}$, $\omega = 377$
 (d) $\mathbf{I}_2 = -0.5 - j1.2$, $\omega = 10^3$

9.16 Using phasors, find:

- (a) $3 \cos(20t + 10^\circ) - 5 \cos(20t - 30^\circ)$
 (b) $40 \sin 50t + 30 \cos(50t - 45^\circ)$
 (c) $20 \sin 400t + 10 \cos(400t + 60^\circ) - 5 \sin(400t - 20^\circ)$

9.17 Find a single sinusoid corresponding to each of these phasors:

- (a) $\mathbf{V} = 40 \angle -60^\circ$
 (b) $\mathbf{V} = -30 \angle 10^\circ + 50 \angle 60^\circ$
 (c) $\mathbf{I} = j6e^{-j10^\circ}$ (d) $\mathbf{I} = \frac{2}{j} + 10 \angle -45^\circ$

9.18 Find $v(t)$ in the following integrodifferential equations using the phasor approach:

- (a) $v(t) + \int v dt = 10 \cos t$
 (b) $\frac{dv}{dt} + 5v(t) + 4 \int v dt = 20 \sin(4t + 10^\circ)$

9.19 Using phasors, determine $i(t)$ in the following equations:

- (a) $2 \frac{di}{dt} + 3i(t) = 4 \cos(2t - 45^\circ)$
 (b) $10 \int i dt + \frac{di}{dt} + 6i(t) = 5 \cos(5t + 22^\circ)$

9.20 The loop equation for a series RLC circuit gives

$$\frac{di}{dt} + 2i + \int_{-\infty}^t i dt = \cos 2t$$

Assuming that the value of the integral at $t = -\infty$ is zero, find $i(t)$ using the phasor method.

- 9.21 A parallel RLC circuit has the node equation

$$\frac{dv}{dt} + 50v + 100 \int v dt = 110 \cos(377t - 10^\circ)$$

Determine $v(t)$ using the phasor method. You may assume that the value of the integral at $t = -\infty$ is zero.

Section 9.4 Phasor Relationships for Circuit Elements

- 9.22 Determine the current that flows through an $8\text{-}\Omega$ resistor connected to a voltage source $v_s = 110 \cos 377t$ V.
- 9.23 What is the instantaneous voltage across a $2\text{-}\mu\text{F}$ capacitor when the current through it is $i = 4 \sin(10^6t + 25^\circ)$ A?
- 9.24 The voltage across a 4-mH inductor is $v = 60 \cos(500t - 65^\circ)$ V. Find the instantaneous current through it.
- 9.25 A current source of $i(t) = 10 \sin(377t + 30^\circ)$ A is applied to a single-element load. The resulting voltage across the element is $v(t) = -65 \cos(377t + 120^\circ)$ V. What type of element is this? Calculate its value.
- 9.26 Two elements are connected in series as shown in Fig. 9.40. If $i = 12 \cos(2t - 30^\circ)$ A, find the element values.

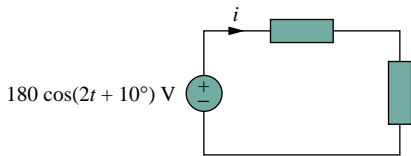

Figure 9.40 For Prob. 9.26.

- 9.27 A series RL circuit is connected to a 110-V ac source. If the voltage across the resistor is 85 V, find the voltage across the inductor.
- 9.28 What value of ω will cause the forced response v_o in Fig. 9.41 to be zero?

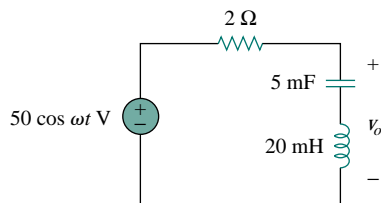

Figure 9.41 For Prob. 9.28.

Section 9.5 Impedance and Admittance

- 9.29 If $v_s = 5 \cos 2t$ V in the circuit of Fig. 9.42, find v_o .

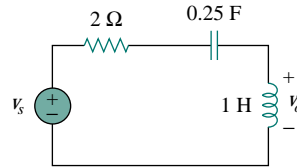

Figure 9.42 For Prob. 9.29.

- 9.30 Find i_x when $i_s = 2 \sin 5t$ A is supplied to the circuit in Fig. 9.43.

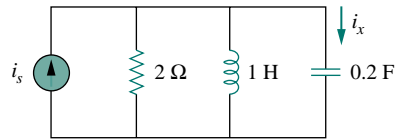
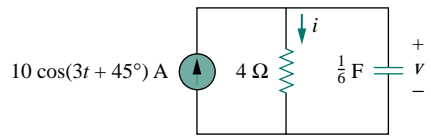
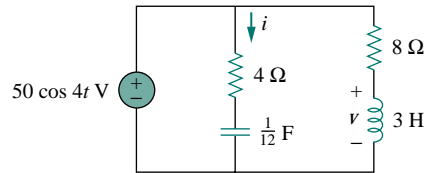

Figure 9.43 For Prob. 9.30.

- 9.31 Find $i(t)$ and $v(t)$ in each of the circuits of Fig. 9.44.



(a)



(b)

Figure 9.44 For Prob. 9.31.

- 9.32 Calculate $i_1(t)$ and $i_2(t)$ in the circuit of Fig. 9.45 if the source frequency is 60 Hz.

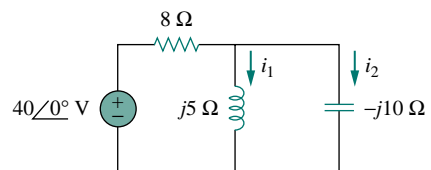

Figure 9.45 For Prob. 9.32.

- 9.33** In the circuit of Fig. 9.46, find i_o when:
 (a) $\omega = 1$ rad/s (b) $\omega = 5$ rad/s
 (c) $\omega = 10$ rad/s

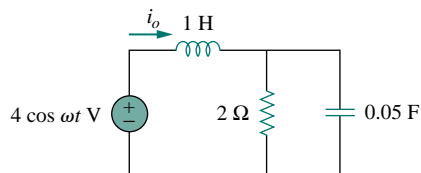

Figure 9.46 For Prob. 9.33.

- 9.34** Find $v(t)$ in the RLC circuit of Fig. 9.47.

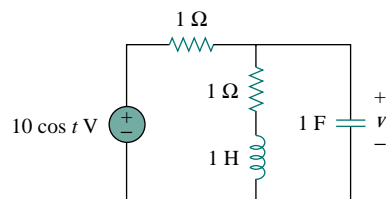

Figure 9.47 For Prob. 9.34.

- 9.35** Calculate $v_o(t)$ in the circuit in Fig. 9.48.

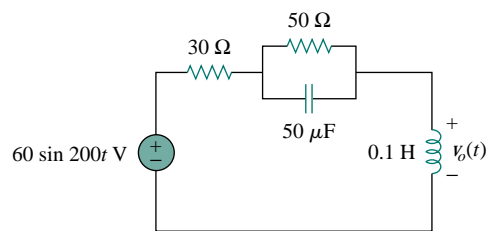

Figure 9.48 For Prob. 9.35.

- 9.36** Determine $i_o(t)$ in the RLC circuit of Fig. 9.49.

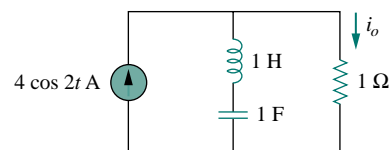

Figure 9.49 For Prob. 9.36.

- 9.37** Calculate $i(t)$ in the circuit of Fig. 9.50.

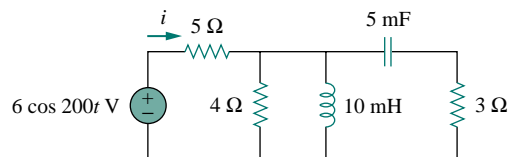

Figure 9.50 For Prob. 9.37.

- 9.38** Find current I_o in the network of Fig. 9.51.

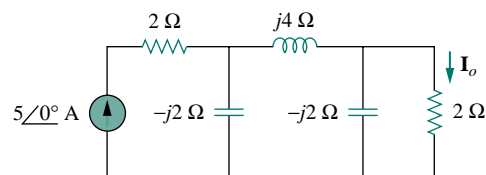

Figure 9.51 For Prob. 9.38.

- 9.39** If $i_s = 5 \cos(10t + 40^\circ)$ A in the circuit in Fig. 9.52, find i_o .

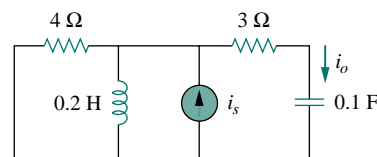

Figure 9.52 For Prob. 9.39.

- 9.40** Find $v_s(t)$ in the circuit of Fig. 9.53 if the current i_x through the 1-Ω resistor is $0.5 \sin 200t$ A.

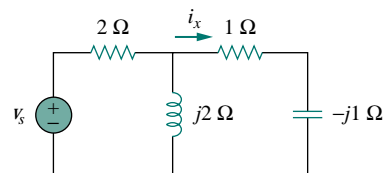

Figure 9.53 For Prob. 9.40.

- 9.41** If the voltage v_o across the 2-Ω resistor in the circuit of Fig. 9.54 is $10 \cos 2t$ V, obtain i_s .

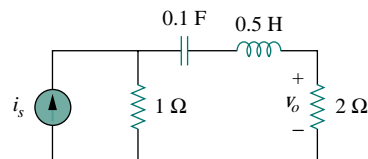

Figure 9.54 For Prob. 9.41.

- 9.42 If $V_o = 8\angle 30^\circ$ V in the circuit of Fig. 9.55, find I_s .

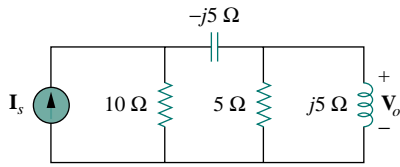

Figure 9.55 For Prob. 9.42.

- 9.43 In the circuit of Fig. 9.56, find V_s if $I_o = 2\angle 0^\circ$ A.

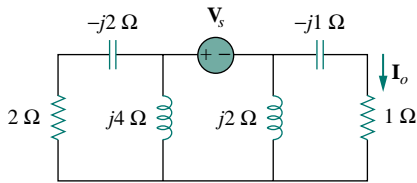

Figure 9.56 For Prob. 9.43.

- 9.44 Find Z in the network of Fig. 9.57, given that $V_o = 4\angle 0^\circ$ V.

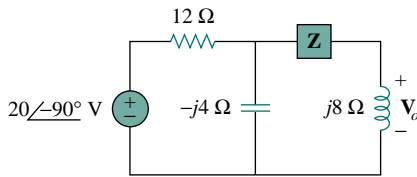
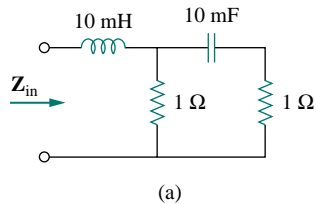

Figure 9.57 For Prob. 9.44.

Section 9.7 Impedance Combinations

- 9.45 At $\omega = 50$ rad/s, determine Z_{in} for each of the circuits in Fig. 9.58.



(a)

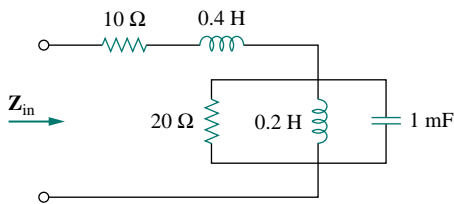

(b)

Figure 9.58 For Prob. 9.45.

- 9.46 Calculate Z_{eq} for the circuit in Fig. 9.59.

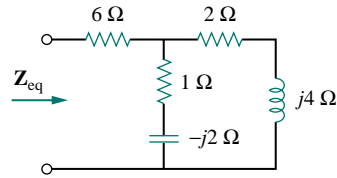

Figure 9.59 For Prob. 9.46.

- 9.47 Find Z_{eq} in the circuit of Fig. 9.60.

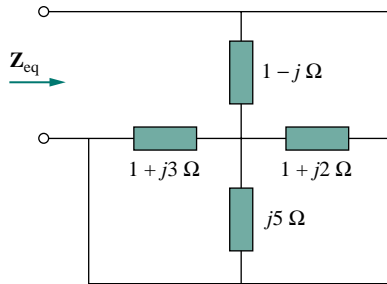

Figure 9.60 For Prob. 9.47.

- 9.48 For the circuit in Fig. 9.61, find the input impedance Z_{in} at 10 krad/s.

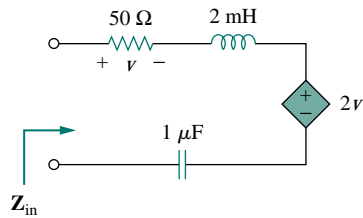

Figure 9.61 For Prob. 9.48.

- 9.49 Determine I and Z_T for the circuit in Fig. 9.62.

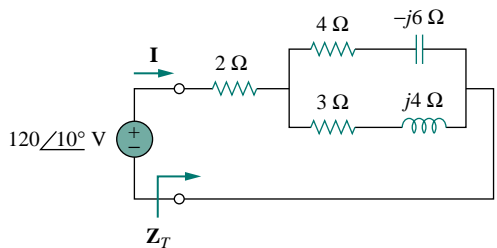

Figure 9.62 For Prob. 9.49.

9.50 For the circuit in Fig. 9.63, calculate Z_T and V_{ab} .

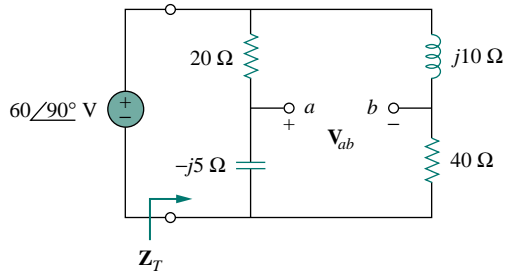
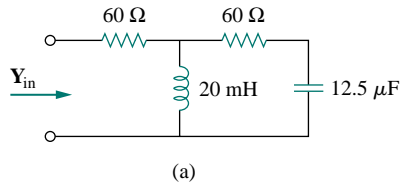
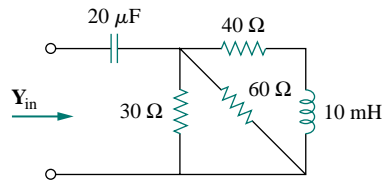

Figure 9.63 For Prob. 9.50.

9.51 At $\omega = 10^3$ rad/s, find the input admittance of each of the circuits in Fig. 9.64.



(a)



(b)

Figure 9.64 For Prob. 9.51.

9.52 Determine Y_{eq} for the circuit in Fig. 9.65.

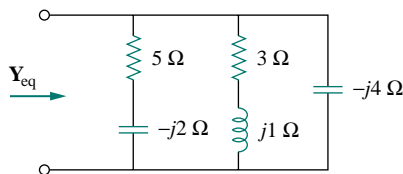

Figure 9.65 For Prob. 9.52.

9.53 Find the equivalent admittance Y_{eq} of the circuit in Fig. 9.66.

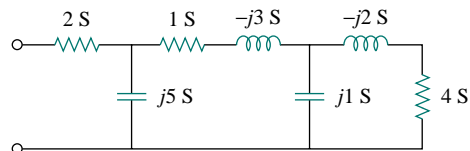

Figure 9.66 For Prob. 9.53.

9.54 Find the equivalent impedance of the circuit in Fig. 9.67.

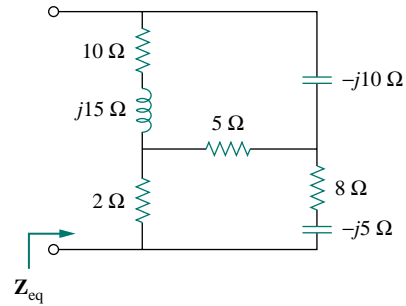

Figure 9.67 For Prob. 9.54.

9.55 Obtain the equivalent impedance of the circuit in Fig. 9.68.

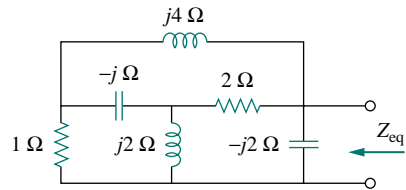

Figure 9.68 For Prob. 9.55.

9.56 Calculate the value of Z_{ab} in the network of Fig. 9.69.

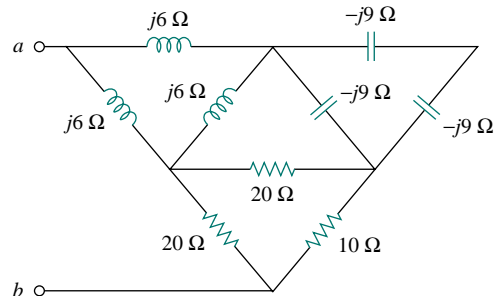

Figure 9.69 For Prob. 9.56.

9.57 Determine the equivalent impedance of the circuit in Fig. 9.70.

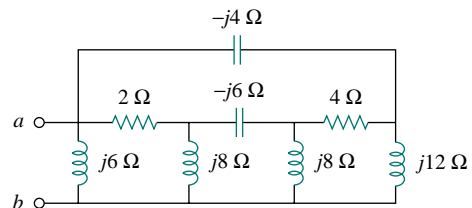

Figure 9.70 For Prob. 9.57.

Section 9.8 Applications

- 9.58** Design an RL circuit to provide a 90° leading phase shift.
- 9.59** Design a circuit that will transform a sinusoidal input to a cosinusoidal output.
- 9.60** Refer to the RC circuit in Fig. 9.71.
- Calculate the phase shift at 2 MHz.
 - Find the frequency where the phase shift is 45° .

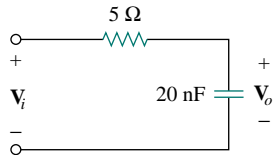

Figure 9.71 For Prob. 9.60.

- 9.61**
- Calculate the phase shift of the circuit in Fig. 9.72.
 - State whether the phase shift is leading or lagging (output with respect to input).
 - Determine the magnitude of the output when the input is 120 V.

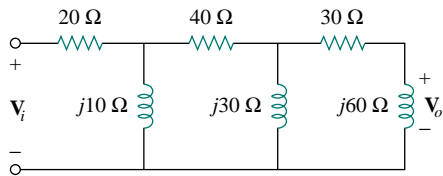

Figure 9.72 For Prob. 9.61.

- 9.62** Consider the phase-shifting circuit in Fig. 9.73. Let $V_i = 120$ V operating at 60 Hz. Find:



- V_o when R is maximum
- V_o when R is minimum
- the value of R that will produce a phase shift of 45°

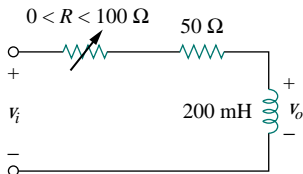

Figure 9.73 For Prob. 9.62.

- 9.63** The ac bridge in Fig. 9.37 is balanced when $R_1 = 400 \Omega$, $R_2 = 600 \Omega$, $R_3 = 1.2$ k Ω , and $C_2 = 0.3 \mu\text{F}$. Find R_x and C_x .

- 9.64** A capacitance bridge balances when $R_1 = 100 \Omega$, $R_2 = 2$ k Ω , and $C_s = 40 \mu\text{F}$. What is C_x , the capacitance of the capacitor under test?

- 9.65** An inductive bridge balances when $R_1 = 1.2$ k Ω , $R_2 = 500 \Omega$, and $L_s = 250$ mH. What is the value of L_x , the inductance of the inductor under test?

- 9.66** The ac bridge shown in Fig. 9.74 is known as a *Maxwell bridge* and is used for accurate measurement of inductance and resistance of a coil in terms of a standard capacitance C_s . Show that when the bridge is balanced,

$$L_x = R_2 R_3 C_s \quad \text{and} \quad R_x = \frac{R_2}{R_1} R_3$$

Find L_x and R_x for $R_1 = 40$ k Ω , $R_2 = 1.6$ k Ω , $R_3 = 4$ k Ω , and $C_s = 0.45 \mu\text{F}$.

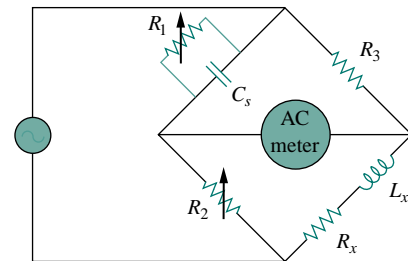

Figure 9.74 Maxwell bridge; for Prob. 9.66.

- 9.67** The ac bridge circuit of Fig. 9.75 is called a *Wien bridge*. It is used for measuring the frequency of a source. Show that when the bridge is balanced,

$$f = \frac{1}{2\pi \sqrt{R_2 R_4 C_2 C_4}}$$

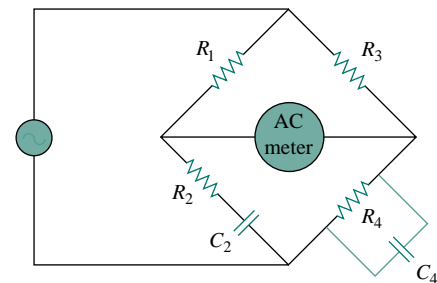

Figure 9.75 Wien bridge; for Prob. 9.67.

COMPREHENSIVE PROBLEMS

- 9.68 The circuit shown in Fig. 9.76 is used in a television receiver. What is the total impedance of this circuit?

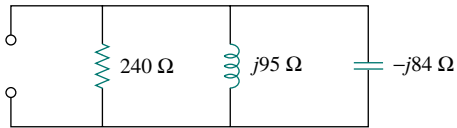

Figure 9.76 For Prob. 9.68.

- 9.69 The network in Fig. 9.77 is part of the schematic describing an industrial electronic sensing device. What is the total impedance of the circuit at 2 kHz?

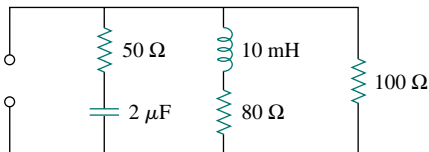

Figure 9.77 For Prob. 9.69.

- 9.70 A series audio circuit is shown in Fig. 9.78.
 (a) What is the impedance of the circuit?
 (b) If the frequency were halved, what would be the impedance of the circuit?

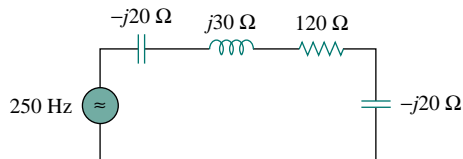

Figure 9.78 For Prob. 9.70.

- 9.71 An industrial load is modeled as a series combination of a capacitance and a resistance as shown in Fig. 9.79. Calculate the value of an inductance L across the series combination so that the net impedance is resistive at a frequency of 5 MHz.

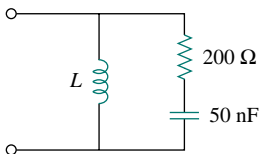

Figure 9.79 For Prob. 9.71.

- 9.72 An industrial coil is modeled as a series combination of an inductance L and resistance R , as

shown in Fig. 9.80. Since an ac voltmeter measures only the magnitude of a sinusoid, the following measurements are taken at 60 Hz when the circuit operates in the steady state:

$$|\mathbf{V}_s| = 145 \text{ V}, \quad |\mathbf{V}_1| = 50 \text{ V}, \quad |\mathbf{V}_o| = 110 \text{ V}$$

Use these measurements to determine the values of L and R .

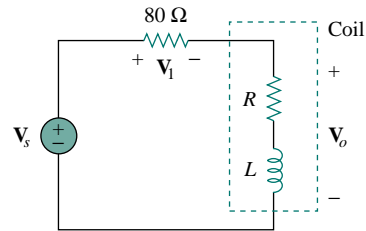

Figure 9.80 For Prob. 9.72.

- 9.73 Figure 9.81 shows a parallel combination of an inductance and a resistance. If it is desired to connect a capacitor in series with the parallel combination such that the net impedance is resistive at 10 MHz, what is the required value of C ?

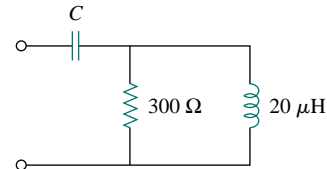

Figure 9.81 For Prob. 9.73.

- 9.74 A power transmission system is modeled as shown in Fig. 9.82. Given the source voltage $\mathbf{V}_s = 115 \angle 0^\circ \text{ V}$, source impedance $\mathbf{Z}_s = 1 + j0.5 \Omega$, line impedance $\mathbf{Z}_\ell = 0.4 + j0.3 \Omega$, and load impedance $\mathbf{Z}_L = 23.2 + j18.9 \Omega$, find the load current \mathbf{I}_L .

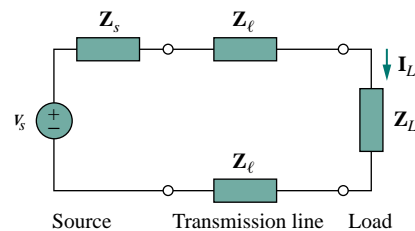

Figure 9.82 For Prob. 9.74.