

Tubular Bell Chimes Design Handbook



By: Leland L. Hite (Lee) www.leeHITE.org/Chimes.htm

Table of Contents

Sample Projects	3
SAY IT WITH CHIMES	7
Background.....	7
Forward	7
Tubes, Pipes or Rods	8
The Build Plan	8
Resources	11
Musical Note Selection	12
A Must Read Caution	13
Chime emulation	13
Strike a Note or Strike a Chord.....	14
Caution At Distance.....	14
Building Big	15
Choice of Metal.....	15
What Metal Sounds Best	16
Not All Tubing is Created Equal	17
Standard Tubing Dimensions.....	17
Chime Dimensions	17
Pre-calculated Dimensions.....	17
Calculate Your Own Dimensions DIY	18
Angle-Cut Tubing	18
Tuning the Chime.....	19
Chime Mechanical Support:	20
First Support Location.....	21
Second Support Location (end cap)	21
Chime Support Suggestions	22
Support Line	26
Nonmetallic Support Line	26
Metallic Support Line	26
Deburring	26
Grommets/Eyelets.....	26
Support Line Suggestions	27
Project Sources	28
Chime-Set Support, Ring, Hoop or Disk & Striker Patterns	28
Support Location Calculator and Points on a Circle Calculator.....	28
Support Disk & Striker Patterns.....	29
Chime Location Sequence	29
Disk and Ring Support Suggestions.....	30
Striker / Clapper	31
Strike Zone.....	31
Striker Shape.....	32
Striker Weight.....	32
Striker Material	33
Keep it Clean	33
Conceal and Carry Chime	33
Striker Suspension.....	34
Striker Motion	34
Striker Clapper Suggestions	35
Wind Sail / Wind Catcher	36
Solving the Dingdong:	37

Need More Dingdong	38
Orthogonal Sailing	38
Windless Chimes	40
Tank Bells & Chimes	40
Length matters, maybe not!	41
Cutting Tanks	42
Decorating the Chime	43
Lightweight coatings	43
Patina, the Aged Copper Look	43
Patina Procedure	44
Sparkling Copper	46
Science of Chiming	46
Loudness Limits	46
Proportional Dimensions:	47
Strike Note vs. Sustaining Note	47
The Missing Fundamental	49
A Bell-like Chime	49
Conclusions	50
Appendix A: The Math	60
Appendix B: Music Scale with Overtones	61
Appendix C: Software Resources	62
Appendix D: Tubing and Rod Sources	62
Appendix E: Standard Tubing Dimensions	63
Aluminum tubing	63
Brass tubing	64
Copper tubing	65
Electrical Metallic Tubing (EMT) aka thin-wall steel conduit	65
Iron pipe	66
Appendix F: Internet Resources/Links	66
Appendix G: Credits	67
Appendix H: Design styles	67
Appendix J: Example for an audible fundamental	68

Cover photo by Chris from Wisconsin, showing his son who is five-feet, six-inches tall. The C9 Chord chime set is 13 feet tall and features aluminum tubing with a 6-inch diameter.

Sample Projects by Website Visitors

Additional details and many more user built chime sets are available on the website [here](#).
Photos by the builders.



Father daughter project by James.



1½" EMT, by David from Alaska.



Aluminum and Brass by Chuck from Columbus



By Kenny Schneider that plays Bach's, Joy of Man's Desiring when struck by a person walking by.



Copper by Gareth Thomas from England.



6-inch aluminum By Craig Hewison from the UK.



2" Aluminum, Traversed Mercator by Caleb Marhooover

Pictured is a sculptural/musical interpretation of the distance which divides my youth from adulthood. Here, this journey is presented through the linear elevation profile of the terrain which fills that divide.



[Chimecloud](#) by Lutz Reiter, Marco



Copper by Dan from Virginia



Cast iron by David.



Gift for a special mother-in-law by Gary Kester. Top support was 3D modeled and printed in PLA+ plastic for this 10-chime



Dan Sodam, 2-inch aluminum, 8-chime Saint Michaels set with keeper incorporates solar lights for nighttime viewing.

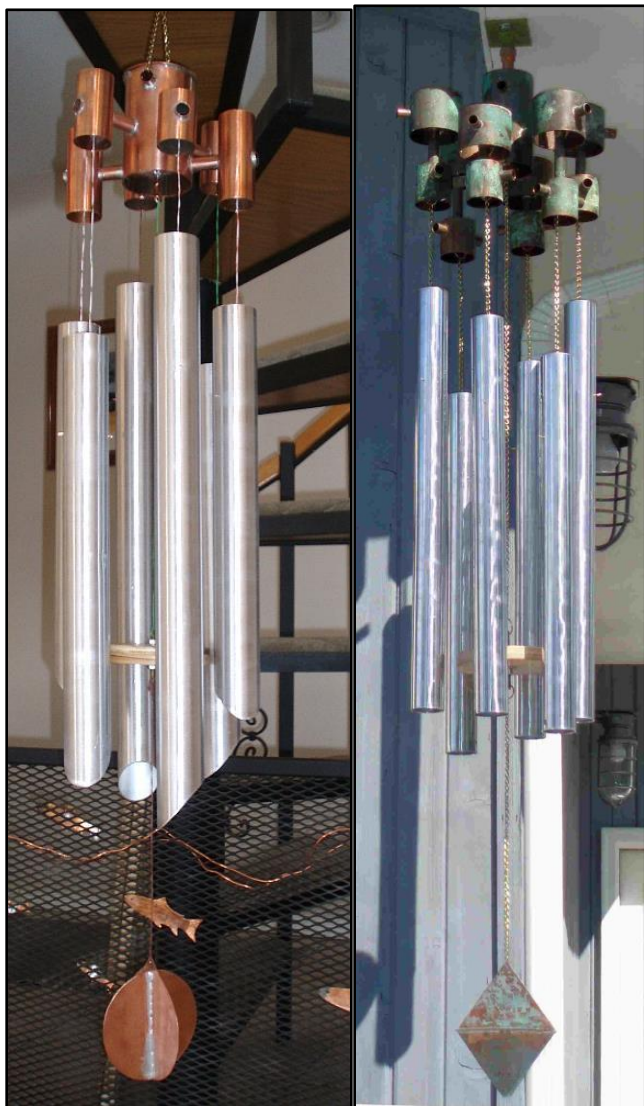

Featuring 2-inch aluminum, Jon selected Alaskan birch for the striker and designed a sculptured support using copper tubing.



Tides by Margaret Noble

Tides was to be a series of dynamic public art concerts with large-scale sculptural kites, tuned wind chimes and performances by experimental choral singers. Formally dressed in black, choral performers were to improvise with varying bell note melodies driven by the kite lines they would fly.



Father-Son project.



Carl Kinder, 1 1/4-inch type-M copper.



2 1/2 inch Aluminum by Neal.



Bill Moyer used eight, one-inch copper pipes with a pentatonic scale tuning beginning at A3, for this artistic arrangement.



Sculptured copper chime support by Nick Leith.



Merle Walther, 1½" painted EMT, 3" wooden ball striker and a Moose wind catcher.



Unique double chime set using 1-inch copper about four feet long flowing across two octaves. By Thomas Warman, Texas.



Tomáš Jarošek from the Czech Republic developed a special tuning for this chime set. See [website](#) for details.



Aluminum by Duc Billy from Viet Nam.

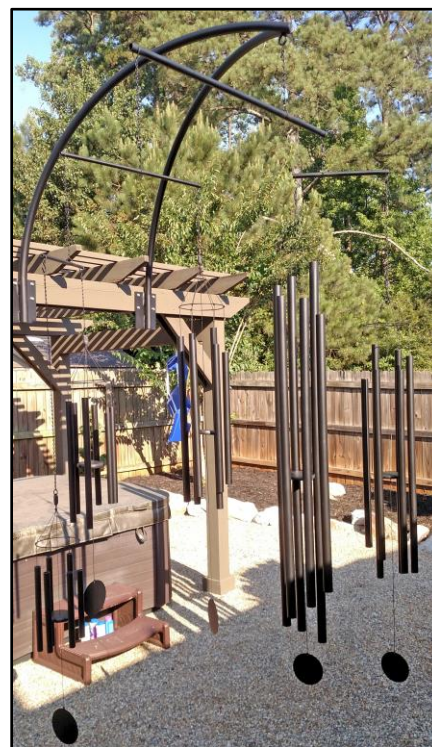

5 - Octave pentatonic scale aluminum chime mobile by Tom Zarzaca from Georgia. Diameters range from 7/8", 1", 1-1/4", 1-1/2", and 2".



SAY IT WITH CHIMES: Providing you with easy options for making good decisions when designing and building tubular-bell wind chimes from tubes, pipes, or rods, is our number one goal. You can build a chime set using the plans detailed below or you can design a chime set specific to your personality and style.

A variety of best practices, patterns and calculators are provided to accommodate your particular skill level, construction resources and budget. Avoid the common mistakes often found in commercial chimes and you can easily construct a great sounding set of tubular bell chimes.

You can anticipate just a few easy decisions before you're ready to begin construction. There is a lot of information in this handbook and on the website, but don't let it overwhelm you. Most of the information provides choices for making a good design decision.

Background: In 2001, when building chime-sets for my daughters as Christmas presents, I asked what makes a chime a good chime. Little did I know what I was getting into when I asked that question. While I would not consider myself an expert by any definition, these findings can be valued for the understanding of tubular bell chimes. My experience with this project has evolved over time and is presented to help you design and build a great set of tubular bell wind chimes. Updates continue almost monthly as development goes forward.

Forward This handbook is a work in progress, so if you spot something that needs clarification or correction, please let me know. [email](#)

Additional resources to this handbook are available for download from the website

leehite.org/Chimes.htm and they include:

1. Precalculated dimensions for the complete note range from C1 thru C9 (tubes total = 75, rods = 90)
2. DIY calculators for the complete note range from C1 thru C9, for the pentatonic scale, and for the C9 chord that determine the correct length and hang point for tubes or rods unrestricted at both ends.
3. Look-up tables for stand size tubing.
4. Standard Music Scale with overtones
5. Look-up table for material properties.
6. An embedded Top Support Disk Calculator allows you to determine the correct layout based on your chime diameter, striker diameter and the clearance between the striker and the chime tube..
7. An embedded location calculator for points on a circle can be used for layout of the top support disk holes or radial star strikers)
8. Chime-set support disk and striker patterns for a 3-chime set thru an 8-chime set, including patterns for either a traditional circular striker or the new radial star striker.
9. Wind sail/wind catcher patterns.
10. Stand alone support disk calculator with points on a circle calculator

Material type = Aluminum, Brass, Cast Iron, Copper, Steel (EMT thin-wall conduit), Stainless Steel and Titanium.

All dimensions are calculate based on the tubing OD (outside diameter) and ID (inside diameter) measured in inches or millimeters and for specific metals. Results are dispalyed in both English and metric units.

The DIY calculator uses nominal values for metal properties. However, if you know the exact metal density and the exact modulus of elasticity, you can enter that data for your specific metal in the data section of the DIY Excel calculator.

Tubes, Pipes or Rods

What's the difference between a pipe and a tube; the way it's measured and its applied use. Pipes are passageways while tubes are for structural builds like hand railing, bicycles and lawn chairs. For the purpose of tubular bell chimes we consider them the same. The important parameters are the outside diameter, the inside diameter and the type of metal.

On the other hand, a rod is a solid metal cylinder that can produce a very different sound compared to a tube. The DIY calculators on this website can predict the resonant frequency for a circular rod and the hang point location. If you want to design and build a chime set using rods rather than tubes all you have to do is set the inside diameter to zero and enter the outside diameter and type of metal into the DIY calculator.

If you are trying to decide between using a tube or a rod as the chime element, one important difference is the sustain time of the musical note. Typically a rod will have a much longer sustain time and in some environments this may be desirable but annoying in others.

Another difference between tubes and rods is their length for a given note. A rod is shorter than a tube to strike the same note for the same metal. For example, a 1 inch steel rod for middle C, (C4) is 26 1/4 inch while 32 7/8 inch is the length for 1 inch steel EMT. In addition to smooth surfaced metal rods, I have tested threaded steel rod and steel rebar. The threaded rod sounded okay but the rebar was awesome. Because of the hardness, rebar exhibited a wonderful sustain time which helped to hold on to the overtones. It was a delightful sound. I did not test the accuracy of the DIY calculator but I suspect it will be close. I would suggest selecting your notes based on steel rod, and while the notes probably will not be accurate, the ratio among the notes should remain the same.

Two additional issues to consider are the weight and loudness difference. Rods typically have a relative smaller diameter than a tube offering a smaller radiating surface producing a quieter chime, but on occasion the longer sustain time can offset the reduced loudness and sound quite acceptable.

The Build Plan

Step 1: Select the number of chimes (typically 3 to 10) for your set and the [musical notes](#). It is helpful to understand the limitations for effective note selection as discussed in the section on [the bell-like chime](#). Keep in mind the physical size for the set. Whether you use pre-calculated dimensions or a DIY calculator, observe the length for the longest chime as a guide for overall size. Remember to include extra length for the wind sail that hangs below the chimes.

Step 2: [Select the metal](#) for the chime tube. See the metals comparison in the video for [How to Make Tubular Bell Wind Chime](#)

Step 3: Cut each chime to the length provided by the pre-calculated table or the DIY calculator. Cut slightly long (about 1/8 inch) to allow for smoothing and deburring the ends to final dimensions.

If you are new to cutting metal and looking for an easy method, I use an abrasive metal cutting saw blade in a radial arm saw. This works equally well with a cut-off saw, aka chop-saw. The blade pictured right is under \$5.00 at Home Depot. The traditional tubing cutter or hacksaw also works well.



Step 4: Smooth the ends to remove sharp edges and to provide a professional appearance. Place an old towel or cloth on a table to protect the chime from scratches. Roll the chime back and forth as you file or sand the ends smooth. Slightly chamfer or round the outer edge.

Step 5: Drill the [support holes at the hang-point location](#) provided by the pre-calculated table or the DIY calculator.

Using a V-block, center the block before drilling by lowering the drill bit to the bottom of the vee and then clamp the block to the drill table.

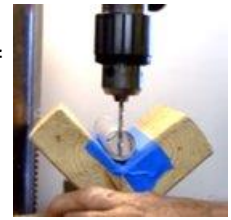

How to drill the tubes without a drill press or V-block: Using card stock or a manila folder, cut a strip about ½ inch by 8 inch, then wrap it around the tube and tape it, so that you now have what looks like a “Cigar Band.” Lay it on a table and flatten it so a crease forms on both sides. Example: Let us say that the instructions asks for a hole 10 ½ inches from the end of the tube. Slide the “Cigar Band” down the tube to the 10 ½ inch. Position one crease at your mark and then rotate the tube over to the second crease and mark that location. Now you have drilling marks exactly opposite each other.

Step 6: Deburr the support holes in preparation for [your support line](#).

Using a drill bit larger than the hole, place the bit on the outside of the hole and rotate by hand. This is generally enough to chamfer the outside hole.

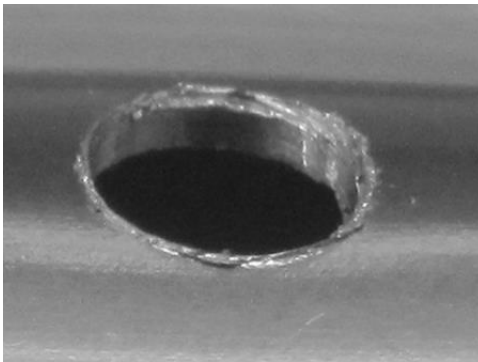

Outside Before



Deburr

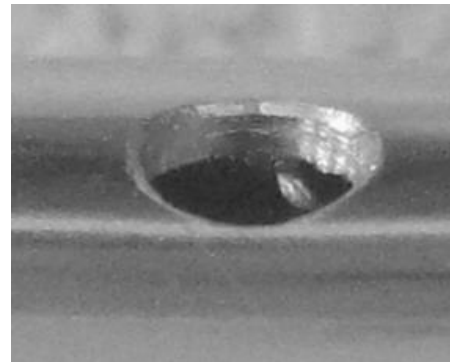

Outside After

Step 7: Deburr the inside support hole. First, using a round or half-round file, remove the burr from inside the tube. Finish the task by using a section of coat hanger wire with a small bend at the far end, as shown right. Place the wire in a drill and insert the bent end thru the hole. As you rotate the wire, lightly pull back on the drill and the bent wire will bend over any inside burr. See picture below.

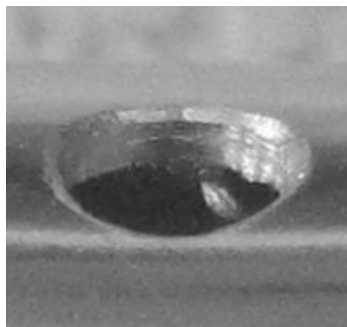

Inside Before

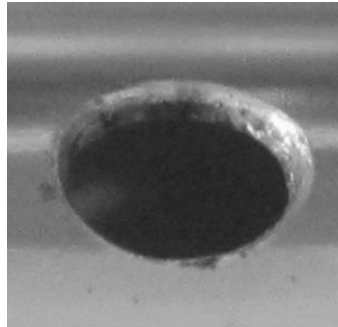

Inside After



Step 8: Select the method or style for [the top support disk or ring](#) and select the material to be used. For a long time, my favorite material was treated lumber used for decking, although it did need a weatherproofing sealer. Also, white, or red cedar works well coated with a weatherproof sealer. The engineered wood for decks makes an excellent support plate and striker. If you know of someone installing a new deck using engineered wood, perhaps you can get a few scraps. One board is expensive and may not be worth the cost, but scraps are useful. Also, a half-inch thick nylon cutting board (old or new) works well. Some people will shop flea markets for that special circular disk made of most anything from metal to plastic plates, etc. In addition, wandering the aisles of Home Depot, Lowe's, Target, Menards and your local drugstore can produce some surprising circular disk that can be drilled and are long lasting in the weather.

Step 9: Select the [top support disk cutout pattern](#) for your specific tubing size and number of chimes in the set. Download the [support disk and striker patterns](#) PDF from the website and just print the page specific to your tubing size and number of chimes in the set. You may need to print two copies, one for the support pattern and holes location, and one for the striker pattern.

Step 10: Select either a circular striker, a radial star striker, or a striker-keeper, all are included in the patterns from step 9.

Step 11: Select and print a pattern for the wind sail from selections in [Patterns for Wind Sails/Catchers](#) PDF available on the website, or design your own.

Step 12: Weather protect the top support disk or ring, the striker and the sail with a UV protective finish. Decorate the chime tube as desired. [A few suggestions here:](#)

Step 13: Select the [line, cord or chain](#) for supporting both the chime tube and the top support disk or ring.

Step 14: Select the [style for hanging the chime tubes](#), i.e. top aligned, center aligned or bottom aligned. Bottom aligned is best because it allows the striker to easily contact the end edge of all chimes, the ideal strike location. Top aligned may have a more aesthetic appeal and on occasion some like center alignment.

Step 15: Select the [sequence for locating the chimes](#) on the support disk or ring.

Step 16: Attach the support line or chain to the chime using a simple [jig you can make here](#). You can use an appropriately sized darning needle for threading line through the top support holes and tubes during assembly.

Step 17: In your workshop, temporarily hang the support disk or ring above eye level. Depending on your chime alignment selection (top, bottom or center) hang each chime according to both the alignment requirement and the chime sequence diagram. Or you can use an alignment jig as described in step 16.

Step 18: Hang the striker according to the alignment diagram and avoid striking exact dead center for any chime. All three locations work well when you keep the striker away from the center dead zone for the first overtone. Do not worry about killing the first overtone with center placement. The first overtone dead zone is very narrow and is easily overcome with a slightly off-center strike.

Musical Note Selection:



A safe choice by many commercial wind chime suppliers has been the pentatonic scale (C D E G A). An enhancement to that scale can be the C9 Chord (C E G Bb and D) which has a wider note separation for a good sound both close in and at a distance from the chime.

With that in mind, we have DIY calculators for all musical notes or for specific scales such as the Pentatonic or the C9 Chord. You select the metal and the tubing size (ID and OD) and the calculator will provide the correct length and hang point for each note.

The longer the chime the lower the notes will sound. So if a specific tuning like Westminster traditionally begins in the C3 octave, like B3-E4-F#4-G#4, feel free to begin an octave lower, like C2, which would look like this, B2-E3-F#3-G#3.

Note Selection Table

Name	Notes	Chimes
Westminster	B3-E4-F#4-G#4	4
Pentatonic Scale	C-D-E-G-A	5
C9 Chord	C-E-G-B ^b - D	5
Corinthian Bells Key of A	A-B-C#-E-F#- A	6
Corinthian Bells Key of C	C-D-E-G-A-C	6
Corinthian Bells Key of Eb	Eb-F-G-Bb-C-Eb	6
Corinthian Bells Key of G	G-A-B-D-E-G	6
Whittington	4-E4-F#4-G4-A4-B4-C#5-D5	6
Canterbury	D4-E4-F#4-G4-A4-B4	6
Trinity	D4-G4-A4-B4-C5-D5	6
Winchester (or Wynchestre)	C4-D4-E4-F4-G4-A4	6
St. Michael's	F4-G4-A4-Bb4-C5-D5-E5-F5	8
Happy Birthday	C5-D-E-F-G-A-A#-Bb-B-C6	9

If you are not sure what notes to select and want to experiment, use the Wind Chime Emulation Designer available on the website. **Caution**, the loudspeaker connected to your computer can play the low notes from C2 to C4, but a chime will not reproduce those sounds.

If the musical scale does not seem logical to you, you are right, it is not logical to most of us non musicians. An octave (a 2 to 1 change in frequency) is from C to the key just prior to the next C, which would be B. Below is a graphical diagram that may help clarify this.

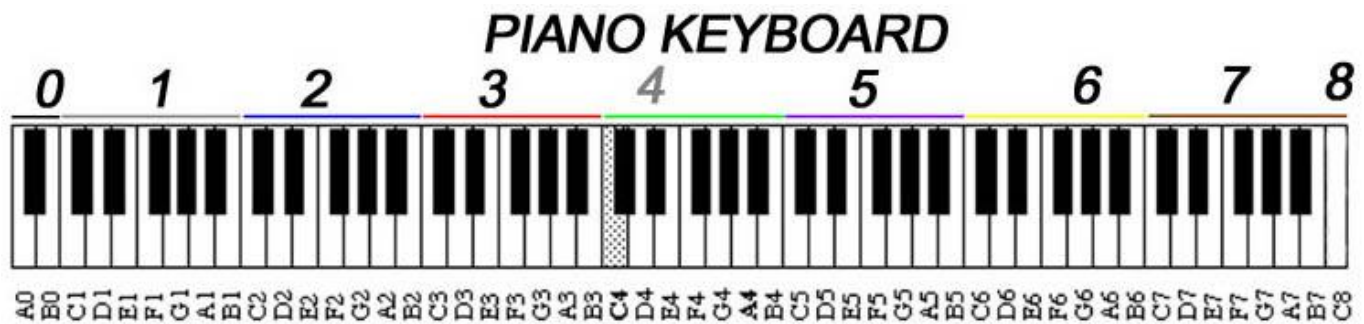

Another Must Read Caution: Ending your project with a successful and pleasing sound is important and setting the right expectations will allow that to happen. Selecting musical notes for a chime is **NOT** like selecting notes on a piano or other string instrument or reed instrument. When you strike C2 on a piano that is indeed what you hear, but **NOT** true for a chime cut for C2.

Tuning implies exactness and exact tuning cannot happen when you do not hear the fundamental note for the chime. When a piano key for C2 (65.4 Hz) is struck, you will indeed hear that note, 65.4 Hz. When a C2 chime is struck you will NOT hear 65.2 Hz. In fact, you will not hear the first overtone at 180 Hz and can barely hear the second overtone at 352 Hz. Most prominent will be the third overtone at 582 Hz which, on a piano, sounds like D5, but is not D5 because the mixing for all the overtones produces a completely new sound. The new sound is melodious, it sounds wonderful, but what note is it?

Tuning charts on the website list dimensions for notes ranging from C1 to C9, that imply exactness, which you now understand cannot happen with a chime when you cannot hear the fundamental note. Read more about the missing fundamental and why this happens in the section "[The Science of Chiming.](#)"

For example, an orchestra grade chime that is physically cut for C2 will sound about like C5. To see a visual representation for what a chime is apt to sound like see this [chart](#). On the other hand, will the strike note for a chime sound pleasing and bell-like? Yes, absolutely, because of the large complement of overtones even though the fundamental is missing. Selections from about C2 to C4 sound the most bell-like but will **NOT** adequately radiate the fundamental tone.

Unfortunately, this effect complicates note selection if you are trying to strike exact notes lower than about C5. Above C5 the strike note will produce the fundamental and you can expect to hear the note you selected, but less bell-like than the C2 to C4 range. For orchestra grade chimes typically begin in the C5 octave and extend to about G6.

Chime Emulation:



Thanks to a site visitor for providing this excellent emulation program

from 1996 by Syntrillium. They are now defunct, and we believe the software is considered "freeware". The zip file contains the main program, the registration codes, and a help file. Unzip the download and run the wind_chimes_1.01_syntrillium.exe file. The program is quite intuitive; full featured and should be easy to operate. To begin I would suggest you set-up the program as follows: Number of Chimes "5", Transpose to "0", Scale to "New Pentatonic", Base Note "C-4", "Center Pendulum".

Remember, the loudspeaker

connected to your computer has the ability to play the low notes from C2 to C4 but a chime may not radiate those sounds. The program was originally designed to run on DOS 6 using Windows 95, and runs with Windows NT, W2000, W XP and W7 thru W10.

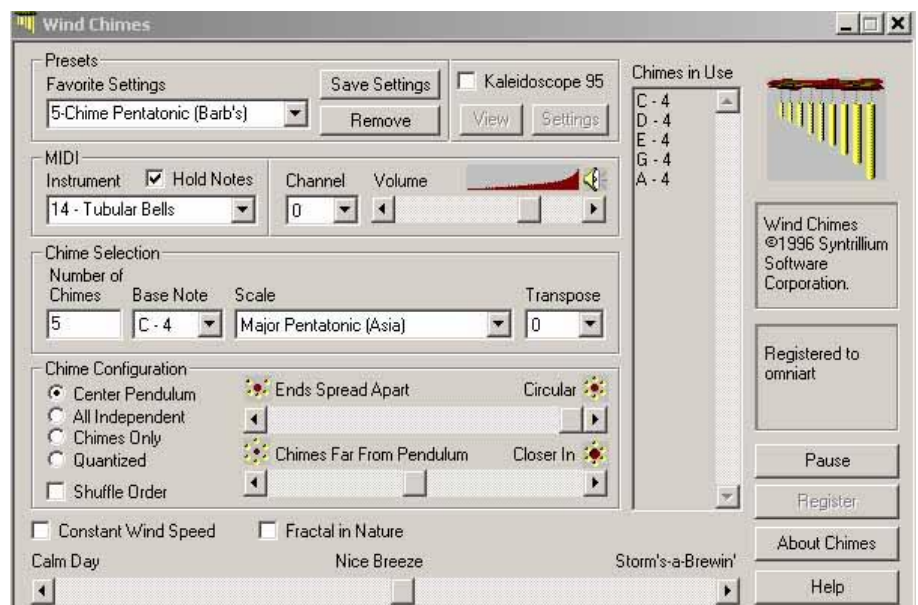



A well designed freeware called Wind Chime Designer V 2.0, 1997-2006, by Greg Phillips will emulate a chime for notes between A2 (110 Hz) thru B8 (7,902 Hz) in many different scales (82 in all). It will help you determine what notes sound pleasant on a chime and what scale to use.

Download the Zip file from the website: Wind Chime Designer Software 370 Kb by Greg Phillips (software + Instructions)

1. Using right mouse, save to a folder of your choice Internet Explorer, select Save Target As Google Chrome, select Save Link As Firefox, select Save Link As Safari, select Download Linked File
2. Click on wind_chime_designer.zip to unzip the folder. (contains Chime32A.exe, TUNING.DAT, and Wind Chime Designer Instructions)
3. Place all three files in a folder of your choice
4. Click on Wind_Chime_Designer_Instructions PDF
5. Click on Chime32A.exe to run the program.

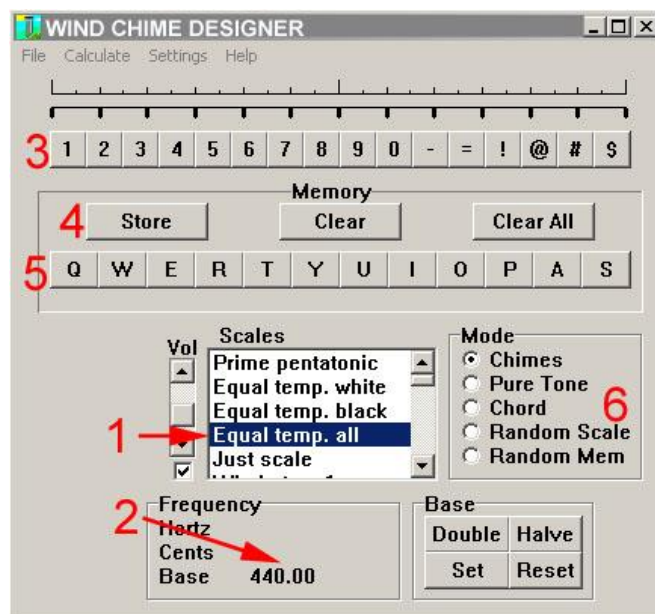

If you have trouble unzipping Greg's new version here are the two files you need. Chime32A.exe and TUNING.DAT Using right mouse, select Save Target As and save to a folder of your choice. Place both files in the same folder and run the .exe file.

Strike a Note or Strike a Chord? Over the years much effort, by many well-intentioned people, has been placed on what is the best chord for a set of wind chimes? While a musical chord can be pleasing to the ear, the effort to simultaneously strike all the notes in a chord using the traditional circular shaped striker/clapper has been mostly a waste of time. The striker only contacts one, maybe two, chimes simultaneously. The good news is that with some of our innovative striker designs we can now strike a chord; more on this in the [striker section](#). Also, if you dedicate a striker to each chime tube (internal or external to the chime) that configuration can ring several chimes at nearly the same time and approximate a chord.

When using the traditional round striker, it is much better to select notes that have a fair amount of separation allowing the ear to easily discern a variety of notes. Often a traditional choice has been the pentatonic scale (C D E G and A.) This choice can sound pleasant close to the chime set but not so well at a distance. The C9 chord (C E G B^b and D) can be used to widen the note separations for a five-chime set. The problem at a distance is the ear has difficulty discerning the closely spaced notes of the pentatonic scale.

Caution At Distance I often hear the comment, "I have a set of chimes on my deck and they sound great. However, I was over to my neighbor's the other day and the chimes did not sound so good. In fact, they sounded out of tune. Why is this?" The answer lies in the conditions that make up the notes for the chime. As mentioned in the science section, a chime note is a combination of the fundamental strike frequency and the many overtones. Some of the overtones attenuate more rapidly than others at a distance. The original combination of strike frequency and overtones are not the same at a distance. Remember, not always does the fundamental frequency contribute to the note and not always are there many overtones for a given note.

The actual note depends on exactly where in the musical scale the chime is operating. When you have a chime that contains a larger number of overtones that are in the higher frequencies, and mostly missing the fundamental, you can get this distance effect. High frequency sounds attenuate more quickly in the

atmosphere than do the lower frequencies. At a distance you are not hearing the same sound you hear close in. Some of the high frequency sounds can be greatly attenuated or missing. The chime can sound completely different under these conditions. Typically, this occurs when you select notes in the lower part of the scale.

If your interest is making the chimes sound good at a distance of say 80-100 feet or more, consider increasing the diameter of the tubing from the traditional sizes ranging from ½ inch thru 2 inch up to at least 3 inch or more: 4 inch to 6 inch are better. A set of chimes designed for the C2 to the C3 octave have good acoustic radiation properties close to the set but not so good far away because of this distance effect.

When it comes to size, if you are on the fence between two sets of chimes, and one set has either a thicker wall or a larger diameter, select the tube with more mass, i.e. thicker wall and/or larger diameter.

Quieting the chime set: Chimes can easily become annoying so maintaining a subtle sound is important, particularly in high winds. Softening the striker often helps in addition the use of the keeper-striker. Typical striker materials are a rubber hockey puck or other soft rubber coverings found in the plumbing section of the local hardware store. Here are a couple examples. The first example uses plastic aquarium tubing to cover the inside diameter of the keeper striker. The second uses a 3-inch and a 4-inch section cut from of a PVC plug for 3- or 4-inch PVC pipe.



D:\DATA\A My Webs\LeeHite.org\chime_pic\quiet keeper-striker.jpg

Building Big: Whether you want a set of large chimes, often used in the sound healing and therapy arts, or you want a large set because of the anticipated lower frequency sounds, similar to a large diameter gong, building big may not accomplish all of your goals. Certainly, a set of long, large diameter chimes as shown on the cover, will sound awesome, but a few words of caution before you head off in that direction.

Since you read the caution statement above about the missing fundamental and the issues with the small sound radiation surface area for a chime tube, you can better understand how the insensitivity of the human ear at low frequencies contributes to our inability to adequately hear the low notes, mostly below about C4. I am often contacted from the website when someone wants to Build Big. After completion of their large chime set, they write to say, "My new chime set sounds wonderful, but not as low as I expected." Beginning with the right expectations will help you move successfully along the design path. Large diameter long chime sets are worth the effort. Be mindful of annoying nearby neighbors since this sound travels far.

Choice of Metal: Most often the chime designer considers cost, weight, and aesthetics. Your budget may not approve the cost of copper while aluminum may be more favorable than steel because of weight. Chimes from EMT (electrical conduit) are galvanized and resist rust, but not at the support hole

or the ends. Rust could be an issue long term for EMT. For the purposes of chime design use the Steel selection in the calculator if you are using EMT.

What Metal Sounds Best? After the issues above are properly considered we can move to the question of what metal sounds best for a tubular chime? The short answer is the thicker the wall and the larger the diameter the better they sound, not necessarily the type of metal. However, what sounds best is a personal choice and I have not found a good answer for everyone. Some like a deep rich sound and other like the tinkle tinkle sound. Copper chimes have a different timbre than steel chimes. The best I can advise is to visit a chime shop and test-drive a few chimes of different metals and different sizes.

When it comes to size if you are on the fence between two sets of chimes and one set has either a thicker wall or a larger diameter, select the tube with more mass, i.e. thicker wall and/or larger diameter.

You may hear someone say they like aluminum best or copper best. To better understand the difference in metals let us properly build two 5-tube sets of chimes using the C9 chord beginning with the C2 octave. One set from aluminum, 2 inch OD with a 1/8 inch wall thickness, and the other set from steel, 2 inch OD with a 1/8 inch wall thickness. While each set will have different calculated lengths, they will both strike the same fundamental note, but sound completely differently. Why is that?

Contrary to intuition there are only two variables that control the sound of a chime, i.e. the density and elasticity of the metal. Those two variables control the length dimensions to achieve a desired note for a given tubing size and wall thickness. From the chart to the right you can see that aluminum has the lowest density and the lowest modulus of elasticity (deforms easier than the others), while copper has the highest density but is only midrange for elasticity.

But what does all of this have to do with what metal sounds best? The differences among metals cause a difference in timbre for the same note.

On occasion you may hear someone say they like aluminum chimes best. That likely occurs because the lower modulus of elasticity for aluminum requires less strike energy for resonant activation and, for a given input of strike energy, the aluminum chime can be louder and have an increased sustain time. However, the difference among metals does not make one metal good and another bad. There are no bad sounding chimes when the notes are properly selected, the tubes are properly tuned and properly mounted. It's impossible to have a set of chimes for the same note range made from aluminum sound the same as a set made from steel or any other metal, because of their difference in density and elasticity.

	Elasticity, psi	Density, Lbm / in ³
Aluminum	10,000,000	0.0980
Brass	17,000,000	0.3080
Cast Iron	13,400,000	0.2600
Copper	16,000,000	0.3226
Steel	30,000,000	0.2835
Titanium	14,900,000	0.1630

If you want the smallest possible chime set for a given note range, select brass tubing. Opposite to brass, EMT will provide the largest physical set for a given note range. As an example, see the table below organized L to R, smallest to largest for middle C (C4). Also see the section on "[proportional dimensions](#)" for considerations of diameter, wall thickness and length.

Length for a one-inch diameter chimes at middle C (C4), smallest to largest.						
Brass .065 wall	Copper M	Cast Iron	Titanium .065 wall	Au.065 wall	Au .035 wall	EMT Steel
26 1/8 inch	27 inch	28 7/16 inch	29 1/8 inch	29 5/16 inch	30 7/16 inch	32 7/8 inch

Not All Tubing is Created Equal: Some tubing may produce a frequency beating effect when struck. This is often due to variations in the cross section of the tubing from variations and inconsistencies in the manufacturing process. The elasticity and the density of the tubing will be different depending on where the tube is struck. The tube can produce two closely spaced fundamental frequencies and these two frequencies will produce the beating effect. Some people enjoy this type of effect and others may find it annoying. If you want to avoid this wah-wah effect, make sure you acquire high quality tubing – or test a small piece before buying in bulk. While some tubing may be considered poor quality for musical requirements, it can be acceptable for structural needs. The problem with tubing that exhibits this effect is that it makes precise tuning more difficult. On the website you can hear this beating sound, for the tube shown to below.

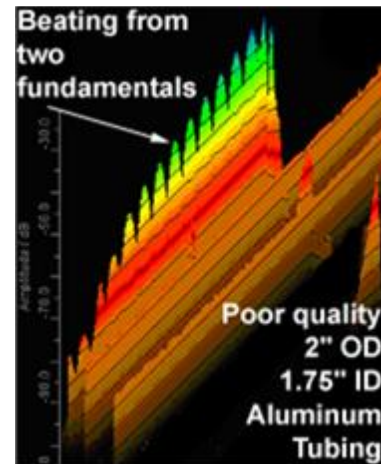

Beating between two fundamental frequencies causing the wah-wah sound effect

If you know the exact material density and modulus of elasticity, enter those parameters into the DIY Calculator on the data page, when using the DIY calculator. I want to emphasize that good tuning will certainly help to accurately produce the appropriate overtones for the selected note, particularly for the higher note ranges.

Standard Tubing Dimensions: see standard dimension tables in [Appendix E](#).

Aluminum and brass tubing tend to exactly follow their listed ID and OD dimensions. However, copper tubing does not. Wall thickness for copper pipe varies with the pipe schedule. The four common copper schedules are named K (thick-walled), L (medium-walled), M (thin-wall), and D W V (drain/waste/vent - non-pressurized).

The printing on the pipe is color coded for identification; **K is Green**, **L is Blue**, **M is Red**, and **D W V is Yellow**. Both type **M** and type **L** can be found in the plumbing section at home improvement stores like Home Depot®, Lowe's®, Menards® and Ace Hardware® and others in the USA.

Commonly available sizes for aluminum, copper, brass, steel and cast iron are also in the [DIY wind chime calculator](#)

Chime Dimensions: Select between pre-calculated dimensions or calculate your own dimensions using the DIY Calculator for common metal tubes, pipes and rods.

Caution: these values allow you to get close to the desired note (typically within 1%) but if you desire an exact frequency, it is best to cut slightly long and grind to the final length. This is not normally required for wind chimes.

Do not use these calculations for an orchestra or a musical setting because an orchestra will typically tune for A4= 442, 43 or 44 Hz and this chart uses A4=440 Hz. Also, orchestra grade chimes typically do not go below the C5 octave. Manufacturing dimensional tolerances may cause slight inaccuracies in the actual results, not to mention the effects of poor material handling along with slight variations in material properties and impurities. If in doubt, cut slightly long and grind to final values. You might be able measure frequency for verification using any of the free apps for an iPhone, iPad, Android or a software programs like [Audacity®](#) See the section ["Tuning the Chime"](#) [Read the caution about chromatic tuners](#) and [the caution on note selection](#)

[Click for pre-calculated Dimensions for Tubes and Pipes \[English and Metric\] PDFs](#)

[Calculate Your Own Dimensions - DIY](#)

All notes calculator Base A4=440 Hz 

Pentatonic scale calculator (C D E G A) Base A4=440 Hz 

C9 chord calculator (C E G B^b D) Base A4=440 Hz 

Westminster Scale Chime Tube Calculator B3-E4-F#4-G#4 

All notes calculator Base A4=432 Hz (Old original tuning) 



For the purpose of chime design use the steel selection in the calculator if you're using EMT (thin wall conduit).

DIY Calculator includes the following features:

- Calculates length and hang point for tubes or rods open at both ends. Tubes with end caps can be adjusted using the ratio calculator.
- Look-up tables for standard size tubing
- Look-up table for material properties
- Standard Music Scale
- All dimensions are calculated based on OD, ID in inches and specific material types
- Answers are displayed in English or Metric values
- OD = outside dimension of tubing (inches), ID = inside dimension of tubing (inches)
- Material type = aluminum, brass, cast iron, copper, steel, stainless steel and EMT (thin wall conduit)
- Note selection by frequency in Hz
- Embedded top support disk calculator
- Embedded points on a circle calculator

The embedded top support disk calculator asks you to decide on the chime diameter (**CD**), the striker diameter (**SD**) and the clearance between the striker and the chime tube (**D**). The calculator provides the correct location for placing the chimes (**R**) and (**CS**), and the diameter of the support disk (**PD**).

Instructions for use are included with the calculator. Also included is a Points on a Circle Calculator for use in the layout of a top support disk holes or a radial star striker.

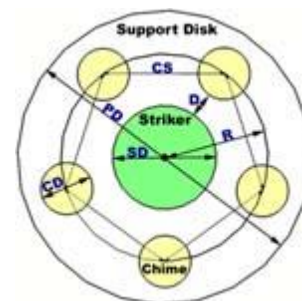

Angle-Cut Tubing: A 45° cut at the bottom or top of the tube can add a nice aesthetic touch; however, the tuning for each chime tube will change considerably from the 90° cut value. The shorter the chime the more the tuning will change. For example, here are the changes for a 5-chime set made from 2-inch OD aluminum with a wall of .115 inch. The set was originally cut for the pentatonic scale (CDEGA) beginning at C6 using 90° cut tubing. After a 45° cut at the bottom end of each tube, the tuning increased from about 5% to 9% depending on length. Unfortunately, the rate of change was not linear, but a value specific to each length of tubing. Tuning increase was C6 =+5.5%, D =+6.6%, E =+7.5%, G =+7.6% and A=+8.8%. This was not surprising because shorting a tube will naturally increase the note frequency.

Additional testing was performed for several different diameters and different lengths using aluminum, copper, and steel tubing. The results were very consistent. Short thin-walled tubing of any diameter changed the most and long thick-walled tubing of any diameter changed the least. Short tubing (around 20 inches) could increase the tuning by as much as 9 to 10%. Long tubing (35 to 40 inches or more) could change as little as 2%. It was impossible to predict the change other than the trend stated



above for short vs. long. This was not surprising because shorting a tube will naturally increase the note frequency.

If you want to maintain exact tuning using a 45° cut, cut the tube longer than the value suggested by the DIY calculator or the pre-calculated tables, and trim to final value using your favorite tuning method. If exact tuning is not required or important, cut the tubing to the suggested length by the calculator to pre-calculated chart, and trim the end at 45°.

Tuning the Chime: If you attempt to create exact notes for an orchestra setting, exact tuning is required and the use of an electronic tuning device or a good tuning ear may be necessary. On the other hand, if you desire a good sounding set of chimes but do not need orchestra accuracy, then carefully cut and finish to the length suggested by the pre-calculated table or the DIY calculators listed above.

Frequency measurement: Measuring the exact frequency and musical note of the chime is challenging at best. **Read the caution below!**

There are a host of apps for Chromatic Tuners available for an iPhone, iPad or Android. Site visitor Mathew George uses “gStrings” on his Android, pictured right.

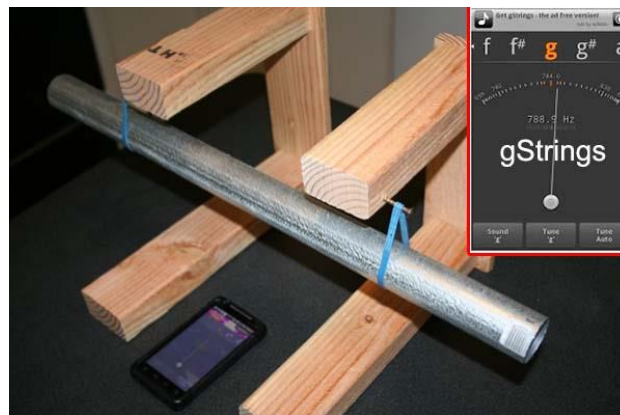

I use the \$.99 app “insTuner” on an iPad and freeware Audacity® on a laptop shown below. A few scrap pieces of wood to make two U-brackets, rubber bands and you are in business. Mark the support nodes 22.4% from each end for locating the rubber bands. If you have just a few measurements to make a quick and easy support is a string slipknot positioned at the 22.4% node, pictured right with the iPad.

A word of caution! It can be challenging and often impossible for a chromatic tuner to measure a chime note correctly. Non-linearity of the human ear and a chime's non-harmonic overtones are two reasons.

Chromatic tuners listen and display sound as it is being produced on a linear basis for both amplitude and frequency, but our brain process the same information using *fuzzy logic*. Why is this problem?

Unfortunately, the human ear is no doubt the most non-linear and narrowband sound listening device we know of. Like other percussion instruments, chimes do not produce fundamental frequencies and pure harmonic frequencies like string instruments, wind tubes and reed instruments, for which chromatic tuners are intended.

Instead, there are numerous non-harmonic overtones present which (depending on their individual frequency and amplitude) can be predominant to a tuner or analyzer but make little or no difference to the human ear. A chromatic tuner may display the predominant amplitude and frequency, but that may not be what the ear perceives. Because of the brain's "fuzzy logic" characteristic, the many overtones associated with a chime fundamental frequency, combine to produce a musical note the brain recognizes, but may not be recognized by a chromatic tuner.



It is difficult to provide an exact recommendation when to use the tuner to measure a chime's note, but in general, I find most any note below C4 difficult to measure, and on occasion, below C5. Long, low frequencies tubes, mostly measure incorrectly because of the "missing fundamental effect" and the preponderance of high amplitude overtones. Thick-walled tank chimes/bells can measure with surprising accuracy because of a single pure tone above C4 that is not cluttered with unimportant sidebands. However, thin-walled tank chimes/bells seem not to do as well, and they may be impossible to measure accurately.

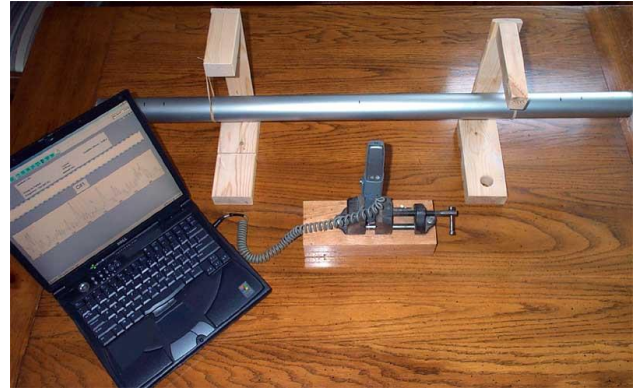

In addition, poor quality tubing exhibiting dual fundamentals will cause the chromatic tuner to constantly switch between the two fundamentals, both of which are incorrect. If you are not displaying the note you expected, try moving the chime further away from the tuner to help minimize unimportant frequencies.

If you get a good steady reading that it is not what you expected, the tuner is listening to a predominant overtone, so just ignore that measurement. Using the values for length provided by the tables and DIY calculators on this page will get you remarkably close to the exact note. If the tuner cannot make a believable measurement, use the calculated length for the tube.

A good software solution for FFT spectrum analysis measurement is a freeware program [Audacity®](#) used on a Laptop pictured above. A few additional sources are listed in [Appendix C](#). Most any computer microphone will work. In fact, I have used the microphone on a headset used for Skype and it works quite well.

To eliminate the annoying background noise when using a microphone, use an accelerometer. I have good success supporting the chime horizontally at one node by a rubber band and at the other node by a thin wire looped around the chime and attached to an accelerometer.

Chime Mechanical Support: The ideal chime support location to allow for a lengthy sustain time is positioned at either of two locations; at the fundamental frequency node located 22.42% from either end, or at the very end using a string or cable threaded through an end cap.

If sustain time is not a requirement (which makes a tubular chime bell sounding) such as for orchestra chimes pictured below, then support can be through horizontal holes near the end of the tube. A chime supported in this manner effectively reduces most of the sustain time and can be a desirable response for an orchestra chime since the strike note is typically the most important musical contribution with minimal sustain time. I do NOT recommend this method of support to achieve a great sounding set of chimes.

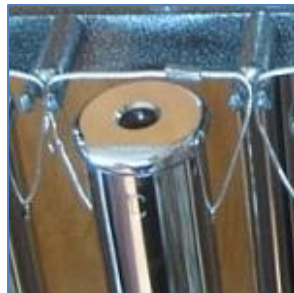

You may see commercial wind chimes supported in this manner, but they cannot support the tradition bell-like sound that you may be expecting. Incorrect support ranks as the number one mistake made by some commercial chimes sets on the internet and in stores. They will produce a strike note but lack the rich resonant bell-like sound that results from proper support.

First Support Location for a bell sounding chime uses the traditional fundamental frequency node, which is 22.42% from either end. See the Transverse vibration mode diagram at the right.

An important objective for a bell-like chime is to preserve the resonance of the chime as long as possible. Accurate placement for the support holes helps to assure the high quality (Q) or hang-time or sustain time for the chime. A hole size of 1/16 inch can be drilled directly on the location mark but for larger holes like 1/8 inch, try to place the top of the hole so it aligns with the location mark.

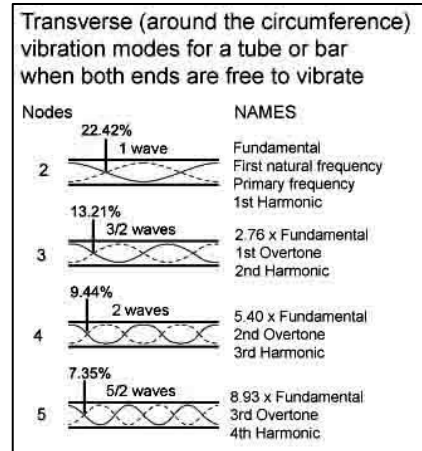

If you are curious about other support locations, it is possible to support the chime at the first, second or third overtone node but not recommended. All charts and calculations in this paper are for the support line to be located at the fundamental frequency node which is 22.42% from either end, and is the optimum location.

If you happen to have a background in both mechanical vibration and acoustic vibration, it is easy to confuse overtones and harmonics. Overtones = Harmonics - 1, or Harmonics = Overtones + 1. This acoustic harmonic relationship has no connection to the radio frequency definition of harmonics. See the diagram below.

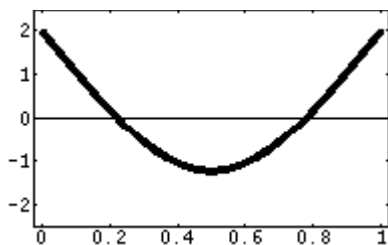

1st Fundamental Frequency

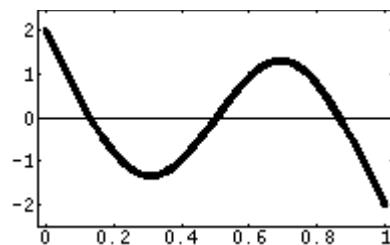

1st Overtone, 2nd Harmonic

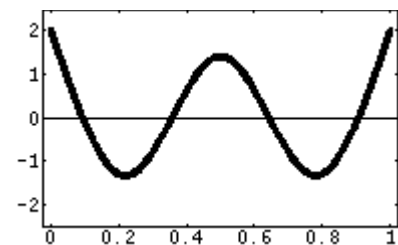

2nd Overtone, 3rd Harmonic

Second Support Location (end cap), is when the chime tube is supported by a cable or cord through a hole in an end cap. It is important to understand that the end cap lowers the fundamental frequency and some associated overtones from values calculated by the DIY calculator or pre-calculated charts. For 1/2 inch copper tubing type L, the fundamental is lowered by about 3% to 6% from calculated values on this page. For 3/4 inch type L copper tubing the fundamental is lowered by about 11% to 12%. The good news is that the end cap noticeably increases the duration for the first overtone and the chime has a much more bell-like sound. Look at the two spectral waterfall displays and specifically compare the hang time of the 1st overtone for each. You will notice a considerable increase in sustain time for the end cap supported tube.

Caution: be certain to solder the end caps in place. An unsoldered or loose-fitting end cap will completely deaden the resonance. An end cap must contact the entire circumference at the end of the chime to function properly.



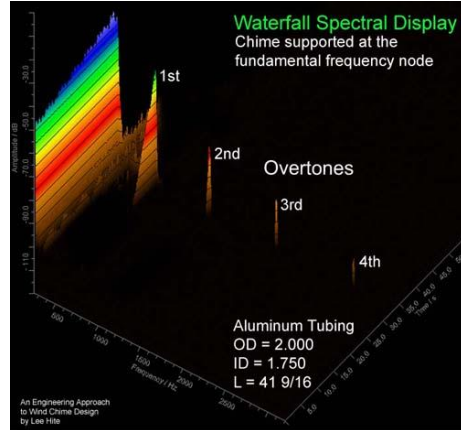
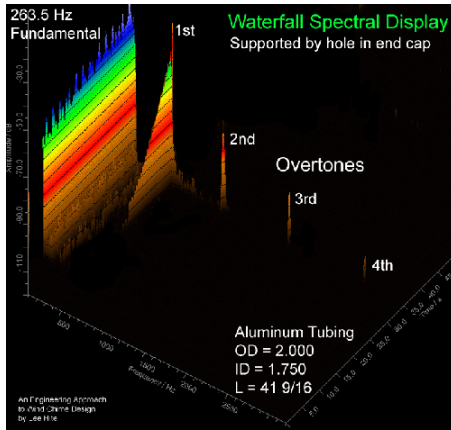

Waterfall display for a chime tube supported by a hole in the end cap like some orchestra chimes.







Waterfall display for a chime tube supported at the traditional fundamental frequency node.



End Support for Rods: It is possible to support a rod at the end and can be easy to accomplish. You might be tempted to inset a screw eye at the end, but I can assure you that will completely kill the resonance. Resonance for a tube or rod can easily be stopped by touching the end. The end cap is a special case that allows resonance to exist without seriously reducing the sustain time. But adding a screw eye or any amount of mass to the end can kill the sustain time for a rod. The easy solution that works very well is to drill a small hole in the end of the rod and epoxy a 50 pound (22 Kg) woven fishing line into the hole. First tie a knot at the end prior to inserting the line into the hole. This low mass and flexible connection do not impact the resonance and provides an easy method for connection.



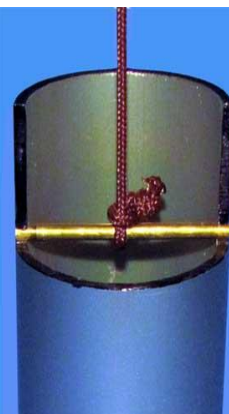
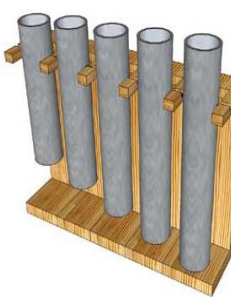
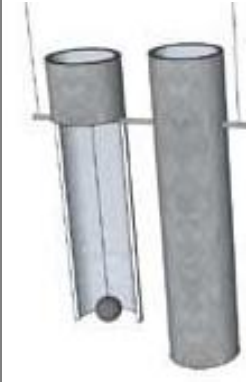

_Chime Support Suggestions

<p>Method 1 Traditional two-point mount and the most stable in high winds for string supported chimes.</p>	<p>Method 1 Important to deburr the outside holes.</p>	<p>Method 1 Eyelets or grommets help when deburring is difficult or impossible.</p>	<p>Method 2 Knot on the outside allows for one top support point.</p>	<p>Method 2 Deburring the inside support hole is important.</p>

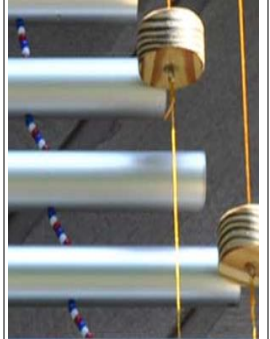
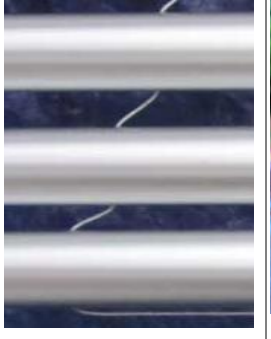
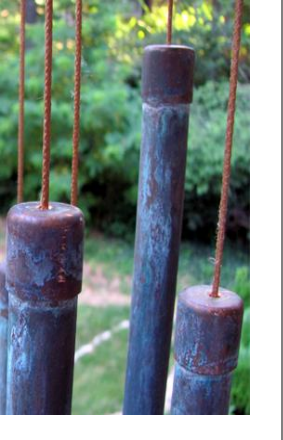
				
<p>Method 3 Converts from a two-point mount to a single point mount and may be more pleasing to the eye with less visible line.</p>	<p>Method 3 Internal view.</p>	<p>Method 3 Side view.</p>	<p>Method 4 1/2 Wrap. Both ends feed from the outside to the inside.</p>	<p>Method 3 The knot can be tucked inside and out of view.</p>
				
<p>Method 4 The half wrap is a convenient connection for a chain mount.</p>	<p>Method 4 Slide the knot out of view for the chain connection.</p>	<p>Method 5 1/8 inch metal rod flush cut and deburred. Held with super glue or flair the ends with a ball-peen hammer.</p>	<p>Method 5 A small rubber grommet on the outside of the chime for each side prevents buzzing.</p>	<p>Method 5 Can be used to support the concealed striker.</p>

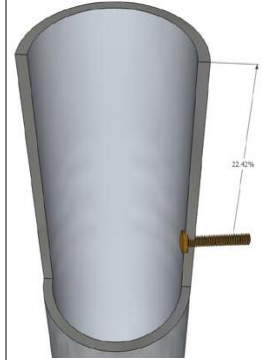
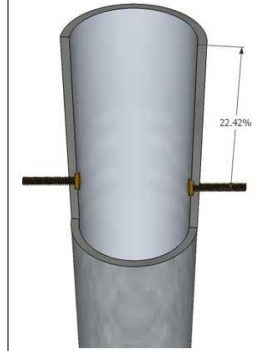
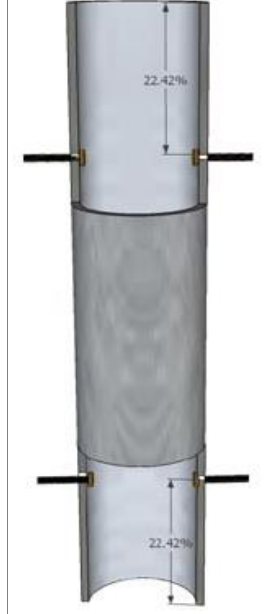
				
<p>Method 6 Horizontal cable mount provides a new look.</p>	<p>Method 6 1/32 inch or 1/16 inch steel cable threads thru each hole.</p>	<p>Method 6 Small plastic beads assure even spacing among tubes.</p>	<p>Method 6 Even without the beads the tubes tend to space evenly.</p>	<p>Method 7 End cap support for copper tubing. Must be soldered to function properly.</p>

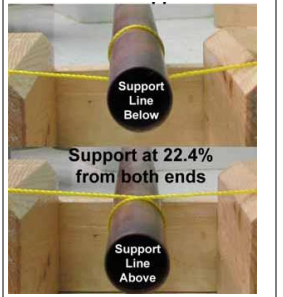
				
<p>Method 8 Rigid mount using 1/8 inch bolt or larger. Securing nut not shown.</p>	<p>Method 8 Dual rigid mount using 1/8 inch bolts or larger. Securing nuts not shown.</p>	<p>Method 8 4-point rigid mount allows maximum support vertically or horizontally.</p>	<p>Method 8 4-point rigid mount resist abuse in a park or playground setting.</p>	<p>Method 9 Horizontal support using a noninvasive soft chord or line.</p>

Forming the inverted V wire pin:

This example uses a number 12 copper wire but you can use aluminum, brass or whatever works best.

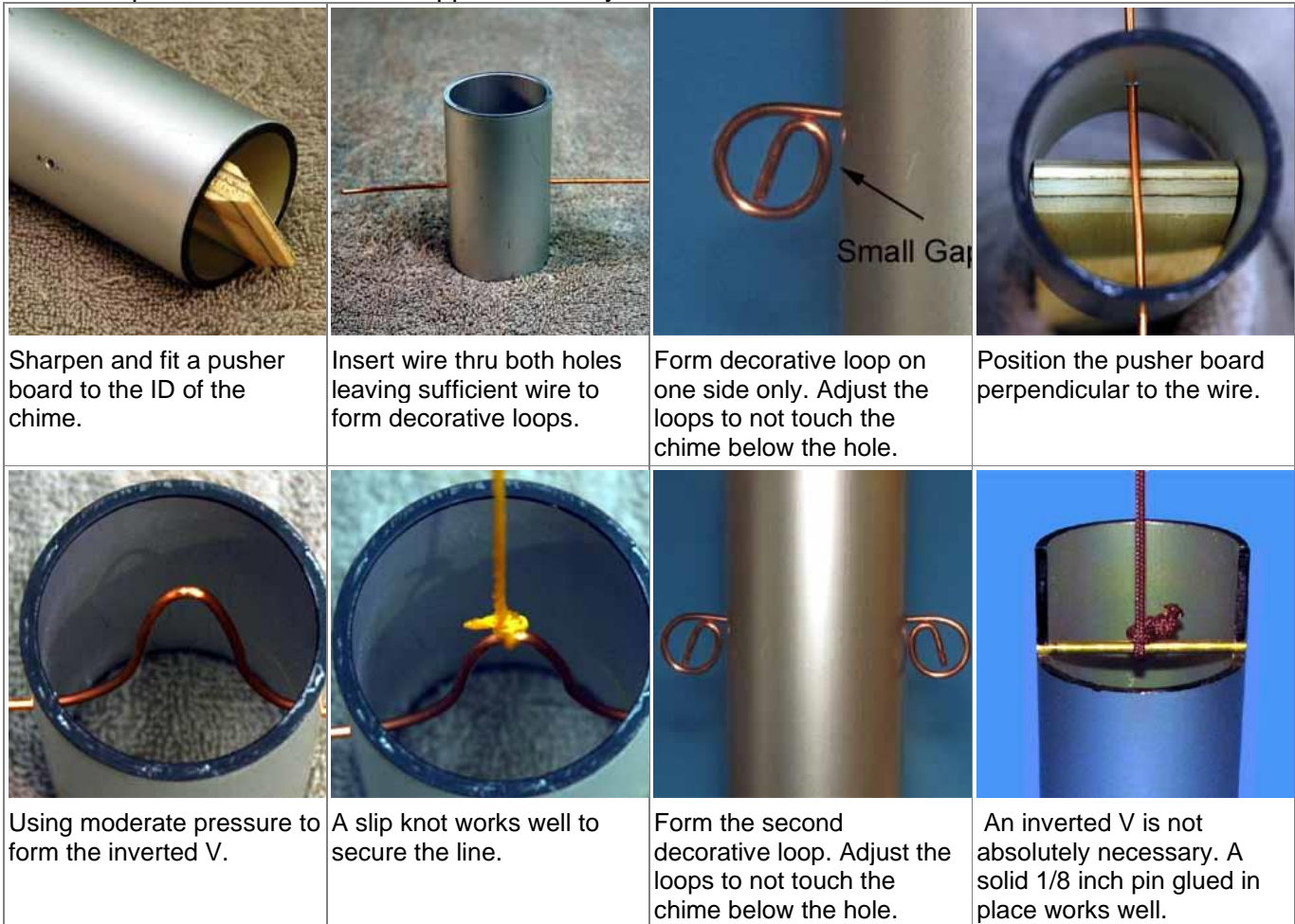

An alternate inverted V support can be the wire arm from a binder clip shown on the right. Remove the wire arms from the clip, stretch them out a little, and position in place using needle nose pliers, wiggle the arm until the tips pop out of the holes. Be sure to attach your hanger line first. The arms tend to be self-centering. The binder clips are available in different sizes so you can match the clip to the diameter of the pipe. The wire diameter increases with the size of the clip so make sure to check before you drill the pipes.

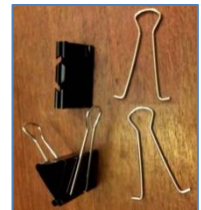

Playground Chimes Support: Pictured right is a set of playground chimes for a full octave (CDEFGABC) from anodized aluminum as depicted on the website External Works. This fun and easy DIY project has a couple of important requirements. First, mounting follows the same requirement as above, i.e. locate the support holes 22.4% from both ends. Rubber grommets help to minimize the reduction of sustain time caused by a firm mounting but are not always necessary for this application. Rubber tends to deteriorate over time and the use of nylon or plastic sleeve would be a good alternate. Firm and strong mounting is a requirement for the playground environment, but we need to prevent squeezing the tube at the mounting location. Careful adjustment, when tightening bolts, can prevent this squeeze. Keep the mounting



somewhat firm to prevent the undesirable BUZZ caused by loose mounting. Flexible grommets allow a firm mounting that will prevent the buzz.

Support Line: I recommend keeping the distance between the chimes and the support desk quite short no matter how they are aligned. This is to assist alignment during high winds. If they dangle too far below to the support plate, they can bump into each other and occasionally get mixed up with each other. A few inches would be best.

Longevity for a chime set is important and careful attention to the support lines and thru holes should be considered. Rapid wind changes and UV light can quickly deteriorate support lines, not to mention the many freeze/thaw cycles.

Nonmetallic Support Line: Make sure the line is UV resistant. Choices include fishing line (either 80 pound (36 Kg) braided or 30-50 pound (12-22 Kg) monofilament), braided nylon line, braided plumb line, braided Dacron kite line, venetian blind chord, string trimmer/weed eater line (.065 inch), awning chord, and braided electrical conduit pull line.

Metallic Support Line: thin wire, decorative chain (zinc plated, brass plated, or painted), 1/32 or /16 inch stainless steel cable (rust resistant), small aircraft control line cable.

Deburring: The support hole requires deburring to minimize line wear. See page 9 for details.

Grommets/Eyelets: are mostly for protecting the outside edge of the thru hole. Rubber, plastic, or metal (grommets or eyelets) are encouraged, but small sizes can be a challenge to locate. Small eyelets can often be located at your local hobby store in the sewing department or a shoe repair store. You can also use the outer shell of a 1/8 inch or 3/16-inch aluminum pop rivet. Remove the nail-like center and use the rivet.

Shown is a jig to position the chime for attaching the support line or chain. After you select the alignment configuration, top, center or bottom, a simple jig can assist the installation of the support line. To the right are three possible jigs, a square-grove jig, and a v-grove jig, both with red adjustable stops for alignment. A third jig made from a section of cardboard or wood strip can work well. Scribe a mark for the bottom, center, or top alignment on the jig. Begin with the longest chime and select an appropriate length for the attachment line from the chime to the support point on the support disk or ring and locate a nail, a pencil mark, or the adjustable post at that location on the jig. Place the longest chime on the template and secure with tape, a clamp or maybe lay a book on it. Stretch the line up to the reference post and tie a loop or a knot or mark with a felt tip pen. Repeat with the remainder of the chime set using the scribed reference mark. For center aligned chimes attach a small section of masking tape to the center of the chime and scribe the chime center location on the tape.

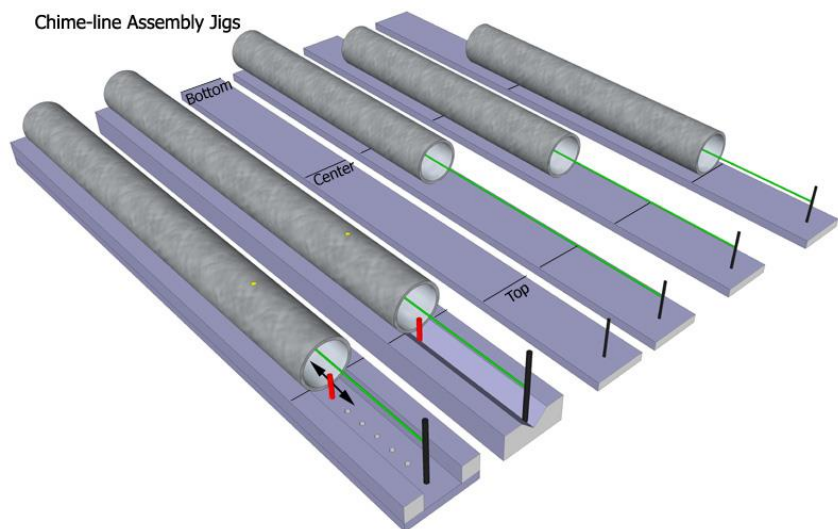

Place the longest chime on the template and secure with tape, a clamp or maybe lay a book on it. Stretch the line up to the reference post and tie a loop or a knot or mark with a felt tip pen. Repeat with the remainder of the chime set using the scribed reference mark. For center aligned chimes attach a small section of masking tape to the center of the chime and scribe the chime center location on the tape.

A knot in the support line or wire can be mostly hidden by use of a countersink hole, when using thru holes to anchor line to a solid support disk. Pictured below are a few examples.

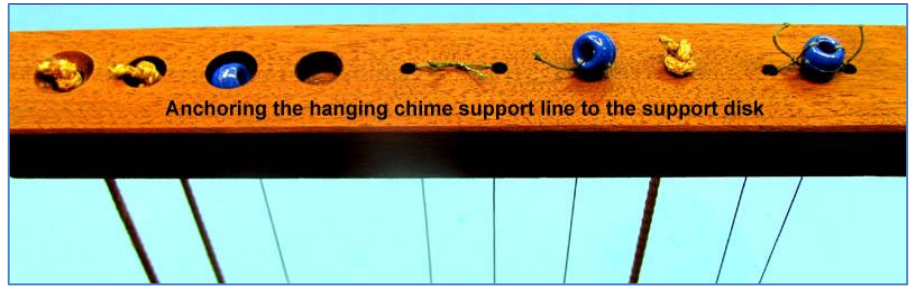

Support Line Suggestions

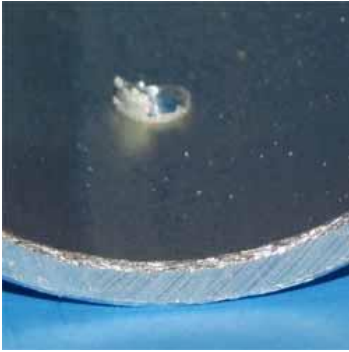

Deburr inside hole using stick and sandpaper.



Chamfer outside hole using an oversized drill bit.



1/8 inch and 3/16 inch aluminum eyelets and a pop rivet.



Outside hole with aluminum eyelet.



Eyelets do not protect the line from the inside edge.



1/8 inch and 3/16 inch eyelets using the shell from a pop rivet. Use only for thru line.



Heat shrink tubing can protect the line from the sharp inside edge of the hole.



Shrinkable tubing in place and operational.



Good place to use heat shrink tubing.

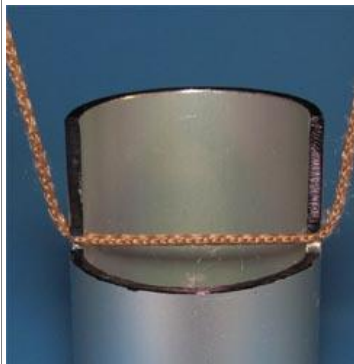



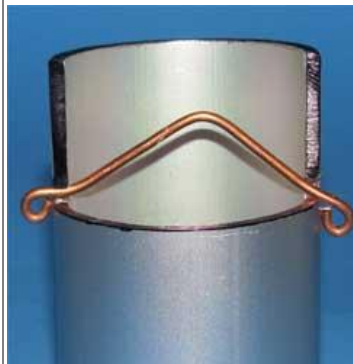

Eyelets required for the outside edge only.



Number 12 copper wire bends easily to form an inverted V.

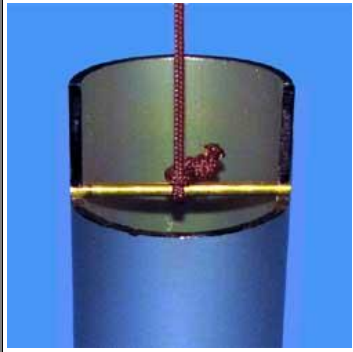

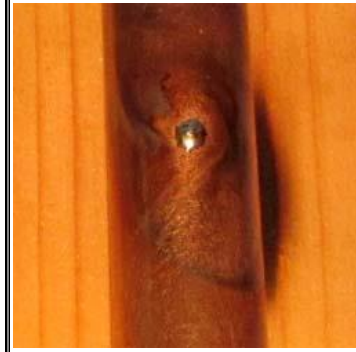
Double support line for an unusually heavy chime.

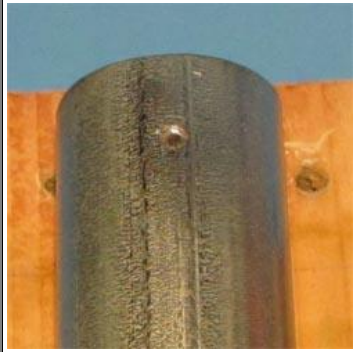
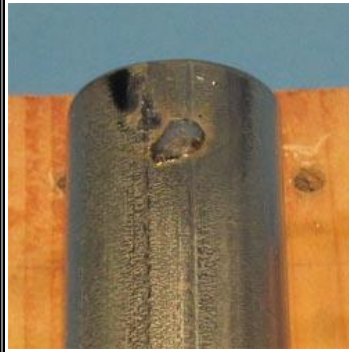
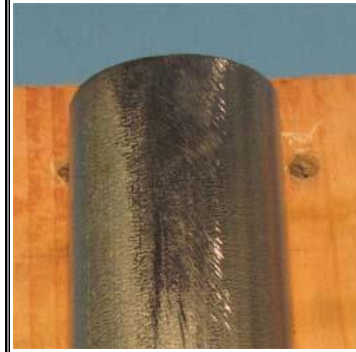
			
Half wrap hides the knot inside the chime.	Solid pin eliminates wear and tear on the connection. Epoxy in place.	For copper or brass tubing, fit a 1/8 inch brass pin into a 1/8 inch hole and file smooth.	Solder or epoxy the pin in place.
			
File smooth and finish the tube with either an aged copper look described below or a clear finish.	For steel tubing, fit a 1/8 inch steel or brass pin into a 1/8 inch hole and file smooth.	Solder or epoxy the pin in place.	File smooth and finish with a decorative paint.

Project Sources: include Home Depot, Menards, Lowes for heat shrink tubing, eyelets from the hobby store in the sewing department or Joann Fabrics. Grommets can be from a hardware store, the model airplane store, or the hobby store.

Chime-Set Support, Ring, Hoop or Disk

Support disk and striker patterns are available in the document to the right. The patterns are for tubing sizes from 1/2 inch to 2 inch in 1/4 inch increments, and for chime sets for 3, 4, 5, 6, 7, and 8 chimes. Generic layout patterns are also included. See [Appendix H](#) for a variety of chime support design styles.



Support Location Calculator and Points on a Circle Calculator 220 Kb

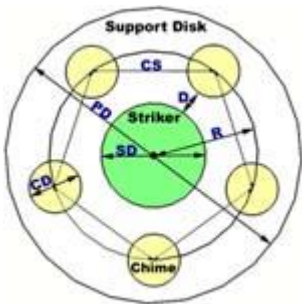

You may wish to calculate your own dimensions for the top support disk using the support disk calculator. You decide the chime diameter (**CD**), the striker diameter (**SD**) and the clearance between the striker and the chime tube (**D**). The calculator provides the correct location for placing the chimes on radius (**R**) and the spacing between the chimes (**CS**), and the diameter of the support disk (**PD**). Instructions for use are included with the calculator.

If you want to avoid using the above calculator, an easy work-around is to select an appropriate generic pattern from the Support disk and striker

patterns document, and scribe the accurate location for support holes using that pattern.

Also included is a location calculator for points on a circle. Uses include automatic calculations for locating chimes on a radius, and points used to draw a multisided polygon such as a star striker or support disk arranged as a star, a pentagon, a hexagon, or an octagon etc. An easy lookup table is provided for locating 3 to 8 points.

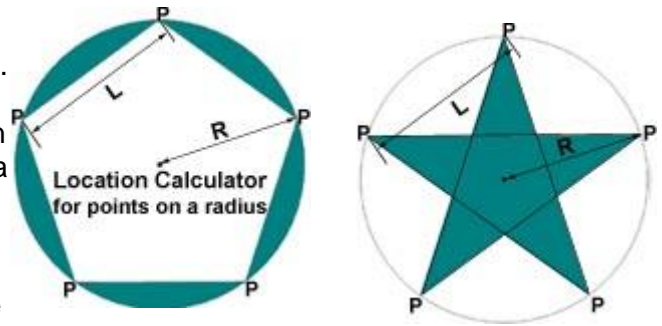

Rather than using a protractor to layout the angles for the shape of your polygon, select the number of points and the radius (**R**) for those points, and the calculator provides you with the distance between points. Adjust a compass to the distance (**L**) and walk the compass around the circle to locate the points.

Chime Location Sequence:

A circular striker will typically strike one chime at a time but can simultaneously strike two chimes. When this happens, you can enhance the overall sound by placing widely separated notes next to each other. For example, below are location suggestions with chime number 1 as the shortest and moving upwards in length as the location numbers increase.

Circular configuration

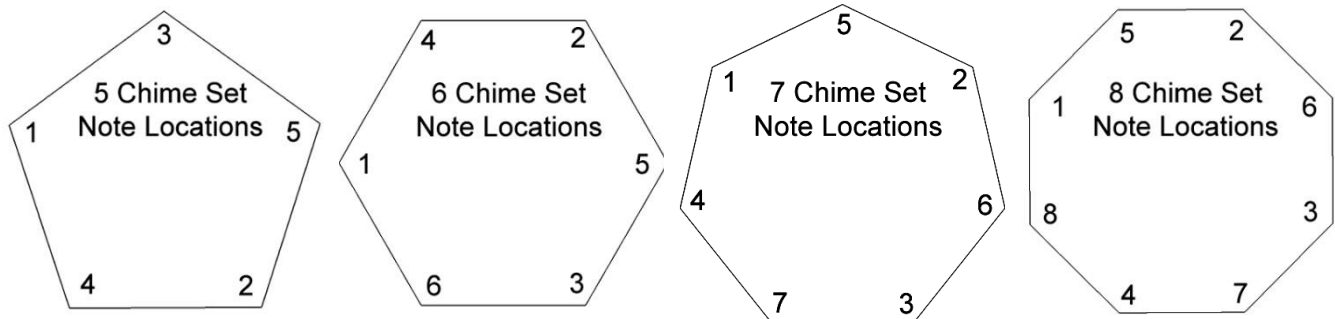









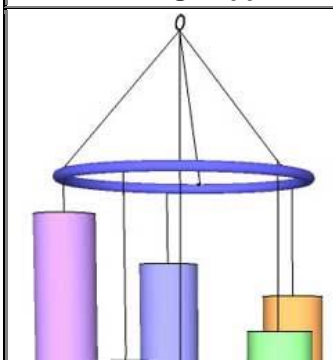



Inline configuration

1 - 3 - 5 - 2 - 4 1 - 4 - 2 - 5 - 3 - 6 1 - 5 - 2 - 6 - 3 - 7 - 4 1 - 5 - 2 - 6 - 3 - 7 - 4 - 8

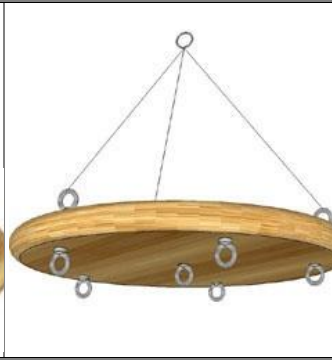
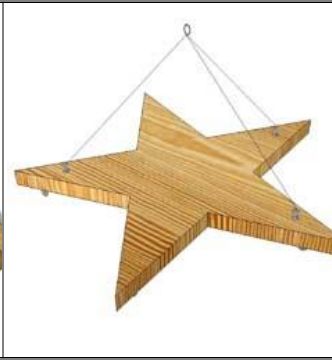

Disk and Ring Support Suggestions

			
<p>A circular ring or hoop provides an open air and transparent appearance.</p>	<p>Support rings can be cut from an out of service aluminum fire extinguisher. Strip paint and brush with a wire wheel.</p>	<p>Use an abrasive metal cutting saw blade in a radial arm saw, a chop saw, or a table saw. Height of 3/8 inch to 3/4 inch "works well.</p>	<p>Chain, decorative cord, or braided fishing line can be used with this top support hoop.</p>
			
<p>Use the generic patterns document to mark the 3-point mount location holes and a generic pattern matching your number of chimes.</p>	<p>Chrome plated steel rings and hoops available in a variety of sizes from hobby stores and online.</p>	<p>Look in hobby stores for rings or hoops often used for dream catchers, mandallas or macramé.</p>	<p>Support disk cut from .075 inch aluminum with a 3/6 inch x 3 inch eye bolt used with the keeper-striker arrangement.</p>
			
<p>A single screw eye is an easy connection but more difficult to balance level.</p>	<p>Chain or UV resistant cord can be configured for a 3-point or 4-point mount.</p>	<p>If the star pattern is used for the striker, it can be duplicated for the top support.</p>	<p>A solid circular disk offers a wide choice for mounting including screw eyes or thru holes.</p>

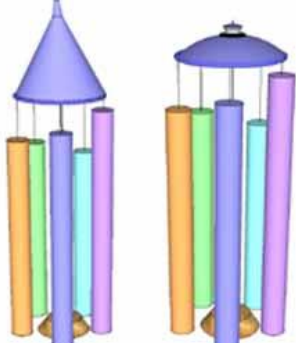
			
You can also use the chime set as a birdhouse.	Bottom view.	Pets, sports logo, or a favorite hobby can adorn the top of the chime disk.	A decorative hand painted funnel or pan lid adds uniqueness to the set.

Striker/Clapper Orchestra chimes, of course, need a human to strike the chime and a rawhide-covered rubber mallet works well. A rawhide-covered baseball or softball can work well for wind chimes but only in an extremely high wind environment where there is ample strike energy from the sail. An orchestra chime is struck with gusto, but a wind chime often has little strike energy. Typically, there is little strike energy from normal winds so preserving and applying that energy is the challenge. Design considerations below include single or multiple strikers, the shape, the weight, the material, the suspension, the motion, and the strike location.

Strike Zone: An important consideration for a bell-like chime is the strike zone. The optimum location is at the very end of the tubular chime because this location will assure that all possible overtones are energized to the maximum. This should not be surprising since orchestra chimes are struck at the end. An easy solution to assuring the strike occurs at the very end of the chime is to use bottom alignment and a tapered striker as shown in striker suggestions.

Often you will see the center selected as the strike location for a tubular bell wind chime, perhaps for aesthetic reasons. When the exact center of the chime is struck the odd numbered overtones can fail to energize, and the resulting sound can be very clunky even though the even numbered overtones were well energized. While I recommend striking the end of the chime, there are good aesthetic reasons to align the chimes for a center alignment or a top alignment. The ideal strike zone is about 1 inch from the end, or about an inch below the center line as pictured below. All three locations work okay when you keep the striker away from dead center, which is a dead zone for the first overtone. Do not worry much about killing the first overtone with center placement. The first overtone dead zone is very narrow and easily overcome with a slightly off-center strike.



Strike zone for top, bottom or center alignment

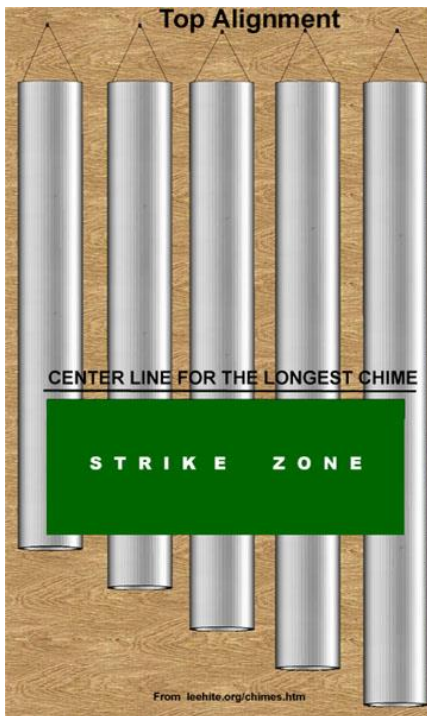

**Strike Zone
Top Aligned Chimes**

Find the center line for the longest chime and position the striker at least an inch or more below that center line. Anywhere in the green section above.



**Strike Zone
Bottom Aligned Chimes**

Find the center line for the shortest chime and position the striker at least an inch or more below that center line. Anywhere in the green section above.



**Strike Zone
Center Aligned Chimes**

Find the center line for all chimes and position the striker at least an inch or more below the center line. Anywhere in the green section above.

Striker Shape is most often circular because the chimes are located in circle. An alternate shape is the circular traveling radial striker which can be effective for striking a musical chord. The radial striker most often takes the shape of an open star or a closed star, like the keeper-striker pictured here. The striker tends to rotate CW and CCW as it bounces to and from each chime. A circular striker will typically contact one or maybe two chimes simultaneously. However, the star shaped striker can synchronously contact most all the chimes. The loudness of the chimes struck with a star striker is somewhat reduced compared to the circular striker because the strike energy has been distributed among the various chimes. See a YouTube video [HERE](#).

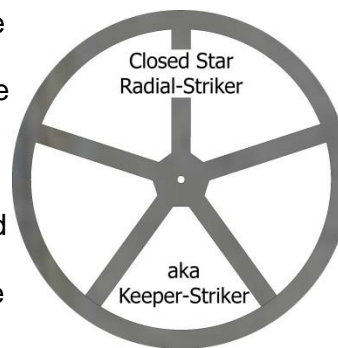

Striker Weight: A heavy striker for large chimes and a lighter weight striker for smaller chimes is a good recommendation most of the time. Depending on your typical wind conditions there may be occasions when you need a lightweight striker for large chimes. Near the seashore winds can be rather strong and you may need to soften the strike with a lightweight striker or switch to a rawhide-covered baseball or softball. Considerable strike energy can be achieved by using an oak disk machined to a knife-edge and loaded with a 1 oz. weight. See [striker suggestions](#) below.

Striker Material: The choice of material depends somewhat on the note selection. If there is good movement from the wind sail, then a circular disk striker (soft sided but heavy) can be used for the larger diameter chimes (say above 2 inches), particularly for lower frequency chimes. Some choices are a hockey puck, redwood, red cedar, treated lumber or a 1/4-inch nylon cutting board. If the wind is quite strong and gusty, you may need to soften the striker even further by using a rawhide-covered baseball/softball. The rawhide helps to produce a very mellow strike in a strong wind. Smaller diameter higher frequency chimes benefit from a harder wood like white oak, teak, or Osage-orange aka hedge-apple. Be sure to coat the striker with a UV resistant coating.

On the other hand, a well performing star-striker should be from a relatively hard material, yet light weight, allowing for a quick response to circular movements. The loudness of chimes struck with a star striker is reduced, compared to the circular striker, because the strike energy has been distributed among the various chimes, and a harder material is required for a strong strike. 1/8-inch soft aluminum, sheet plastic or a 1/4-inch nylon cutting board works well to accomplish both goals.

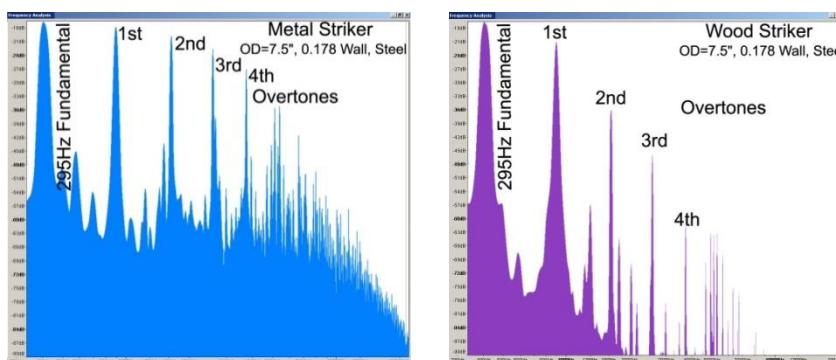

Keep it Clean: A dirty strike can energize a host of unwanted spurious sideband frequencies as demonstrated by the steel striker in the blue spectrum display above.

A most melodious bell sound is achieved with a softer strike that energizes overtones without spurious sidebands, as shown in the purple spectrum display to the far right.

Both strikers produced equal loudness for the fundamental while the steel striker did a better job of energizing overtones (louder) but at the expense of unwanted dirty sidebands. The wood striker (hard maple) produced a most melodious bell sound while the metal strike was harsh and annoying.

Conceal and Carry Chime hides a lead striker on the inside the chime for large diameters chimes, mostly above two inches as pictured left and right. This technique is seldom used unless the chime set is large or becomes annoying, caused by the traditional disk striker in high winds. Because there is insufficient distance for the striker to gain momentum



and strike with gusto, the inside striker could be a good solution to quieting chimes in high winds. If you are looking for a muted sound from a large set, maybe 4 inches and above, this technique is useful. The striker is a lead weight, normally used as a sinker for fishing, and can be any of the following types: a cannon ball sinker, a bell sinker, a bank sinker, or an egg sinker. Wrap the sinker with about two layers of black electrical tape to prevent the harsh sound from a metal strike yet still provide a strong but muted strike. Support for the striker string or line from can be from the same point you use to support the chime tube.

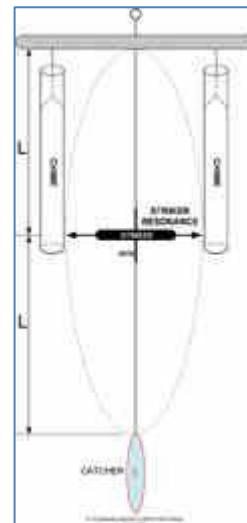

Striker Suspension A small 1/16-inch brass tube about 5 inches long thru the center of the striker allows for the suspension line to be threaded and used as an axle for the disk. This helps to keep the disk horizontal during rapid and sudden movements from high winds. A stiff wire like coat hanger wire can be used as an axle as shown below in [striker suggestions](#).

Striker Motion: I happen to live in a wooded area with little wind and have struggled to achieve good strike energy with low winds. With that in mind, I set out to improve the low wind performance of the striker.

The objective was to maximize striker movement with little input energy from the sail. The easy solution was to resonant the support line that supports both the striker and the sail using the second mode bending principle. This resonance will help to amplify and sustain the motion of the striker with little input energy from the sail. Even though the sail moves in the wind, it will act as an anchor for the resonant movement of the striker.

You can easily recognize this movement by using both hands to hold a string vertically and have a second person pluck the center of the string. The natural resonance of the string will cause the center to vibrate. If you position the striker at the exact center between the top and the sail you can achieve this resonance.

It is difficult to provide an exact ratio between the weight of the striker and the weight of the sail. Depending on the actual weight for both, the ratios can be quite different. In general, when you attempt to resonant the striker line, I suggest the striker not exceed the weight of the sail and ideally the striker should be about 1/2 the weight of the sail. I realize that if you use a CD as the sail a lighter weight striker can be difficult to achieve. A heavy striker is difficult to resonant.

On the other hand, for medium to high winds and for a non-resonant mounting, the wind catcher/sail should have a weight less than 25% of the striker.

When resonance is working well you will notice as the sail comes to rest, the striker will continue to bounce off the chimes for a few more strikes, an indication the striker is dissipating the stored energy from resonance. See this [Resonant striker video](#) WMV, for a demo. Notice the large movement of the striker compared with little movement from the sail

Striker Clapper Suggestions

 <p>Straight edge wood disk striker with axle.</p>	 <p>Knife edge wood disk maximizes strike energy.</p>	 <p>Rigid support stabilizes striker during high winds</p> <p>Knife edge disk striker with weight and axle.</p>	 <p>1 oz weight and knife edge maximize strike energy</p> <p>Close up for tapered edge wood striker with weight and axle.</p>
 <p>Bullet nose wood striker with hollow axle or wire axle maximizes strike energy.</p>	 <p>Enameled coat hanger wire works well for an axle.</p>	 <p>Tapered edge wood striker with axle allows striking the end of the chime edge for maximum strike energy.</p>	 <p>Typical tapered edge striker with axle for bottom aligned chimes.</p>
 <p>Typical arrangement for a tapered edge striker with an axle for bottom alignment.</p>	 <p>A sculptured tapered edge striker adds a decorative touch for striking the edge of the chime end.</p>	 <p>A sculptured tapered edge striker assures contact with the very end edge of the chime.</p>	 <p>Open Star Radial Striker</p> <p>A radial striker rotates on contact with the chime bouncing back and forth effectively striking a chord or most of the chord.</p>

		 <p>Closed Star Radial-Striker aka Keeper-Striker</p>	
<p>The open star radial striker loudness is reduced compared to the traditional round striker.</p>	<p>Multipliable configurations exist to achieve a radial strike. This one might be appropriate for someone working in the nuclear business.</p>	<p>The enclosed star radial striker works great for maintaining alignment in high wind conditions and produces a more subtle strike.</p>	<p>The enclosed star radial striker can be made from 1/8 inch sheet plastic, aluminum or other light weight but relative hard material.</p>
 <p>3-Chime Keeper-Striker OD=9" ID=8" Ribs=1/2" Center hole=1/4" .050 to .075 Thick Aluminum</p>		 <p>5-Chime Keeper-Striker OD=9" ID=8" Ribs=1/2" Center hole=1/4" .05 to .075" thick aluminum</p>	
			
<p>Baseball / Softball good for a mellow strike in a high wind environment.</p>	<p>Conceal and Carry The chime carries a concealed lead striker inside a 2-inch diameter or larger chime and provides a unique style with a more subtle strike.</p>	<p>A 2 oz. lead weight wrapped with two layers of black electrical tape provide a strong but muted strike.</p>	<p>A billiard ball or croquet ball are choices for a strong strike on small chimes. Test first for harshness. Can be too strong for some.</p>

Wind Sail / Wind Catcher The pessimist complains about the wind, the optimist expects it to change, the realist adjusts the sails. By William Arthur Ward

The objective of the wind sail/catcher is to cause the striker to randomly contact all the chime tubes. Traditional wind sails generally work well and can be configured with a variety of materials, sizes and shapes as shown in the document on the right. Patterns 1.3 Meg, PDF

My dissatisfaction with the traditional wind sail is that single-direction winds tend to cause the sail to swing like a pendulum. That arrangement will swing the sail both to



and from the direction of the wind, not allowing the striker to contact adjacent chimes. That affect sounds much like a dingdong, dingdong as the striker hits only two chimes.

As you may know, wind close to the ground can behave differently than winds aloft, and often do not blow horizontally as intuition would suggest. Instead, it is a multidirectional force with an ample amount of wind shear.

To better understand wind turbulence mixed with single-direction winds watch this 20 sec WMV, [Bi-directional wind vane video](#) showing a bi-directional wind vane mounted on my deck. You probably noticed the swirling motion mixed with single-direction winds and the random uphill and downhill movement aka pitch and yaw. Perhaps we can exploit this force to make a better wind sail. Let us take advantage of this turbulence to create a striker movement that is somewhat rotational in nature and does a better job of striking all the chimes.

Solving the Dingdong: The first of several solutions to better capture wind turbulence can be quite simple. Mount the sail at 45° to the horizontal so as to catch the pitch and yaw forces, as pictured on the right. Thread the support line through two small holes next to the center of an old CD disk and tie the knot slightly off-center to create the 45° slope. You may need to glue the line in place for the long term.



A second solution is to hang the sail perfectly horizontal. Counter intuitive, I agree, but depending on your particular type of wind it can work surprising well, particularly if the chime set is hung from a high deck or beyond the first story of the building and the wind is particularly turbulent.

A third solution is to make sure the top support disk can easily rotate in a circular direction. Hang the top support disk not from a fixed ring or hook but from a single support line as pictured to the right. The very nature of the wind will catch enough of the chimes to rotate the entire set allowing the pendulum motion of the sail to strike more of the chimes.

A fourth solution can be the radial traveling star striker described above. The very nature of the star striker is to quickly rotate CW and CCW from any input motion of the sail, even from straight-line winds, and this motion will easily avoid the dingdong sound.

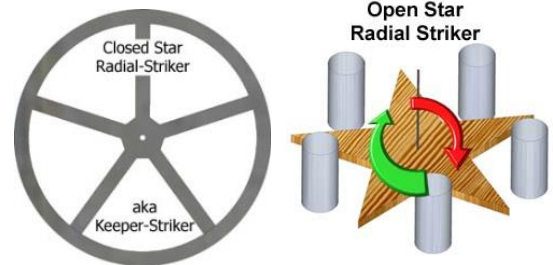

Need More Dingdong: Need More Dingdong? At this point you are most likely saying “WHAT” more dingdong? We just got done solving the dingdong and now you want more! Yes, there is a condition when excessive pendulum movement of the sail is useful and not sufficiently supplied by the tradition wind sail. With the development of the keeper-striker or the radial-striker, both of which are effective in striking a musical chord, there is a need for a robust movement of the striker. The radial striker produces a more muted sound because the strike energy is simultaneously distributed among all the chimes by moving in a circular motion. Thus, the need for a more robust strike.

Jerk, Jolt, Surge and Lurch: We often describe the motion of an object in terms of displacement, velocity, or acceleration. However, an additional motion description seldom used is the rate of change of acceleration. The unit of measurement is often termed jerk but is also known as jolt, surge, or lurch. Jerk supplies the sudden and rapid motion from the wind sail to the rotary keeper-striker.

Introducing Orthogonal Sailing: We have developed a special wind sail to solve the need for more jerk. As mention above, a normal wind sail will mostly swing to and from the direction of the wind; however, the orthogonal sail has the unique ability to fly aggressively at right angles to the wind direction, , thus the name Orthogonal Wind Sail.. If the wind is from the North, the sail will fly East and West.

The aggressive motion of the sail will eventually exceed its ability to fly, fall into a chaotic state and stall. Immediately the process repeats and continues to supply considerable energy to the radial striker. The design is simple and easy to build, see below

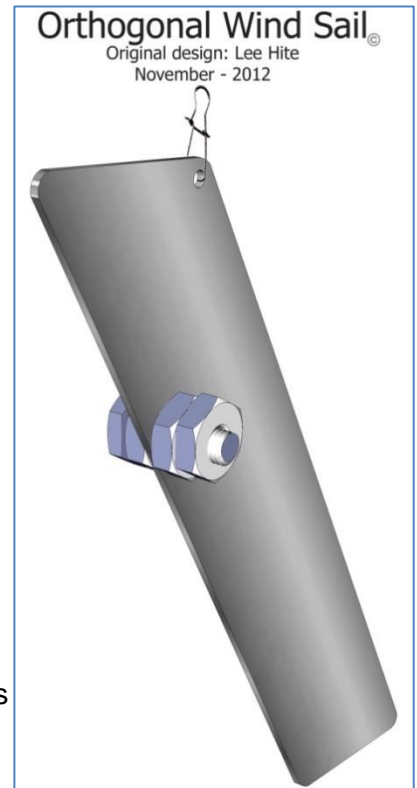

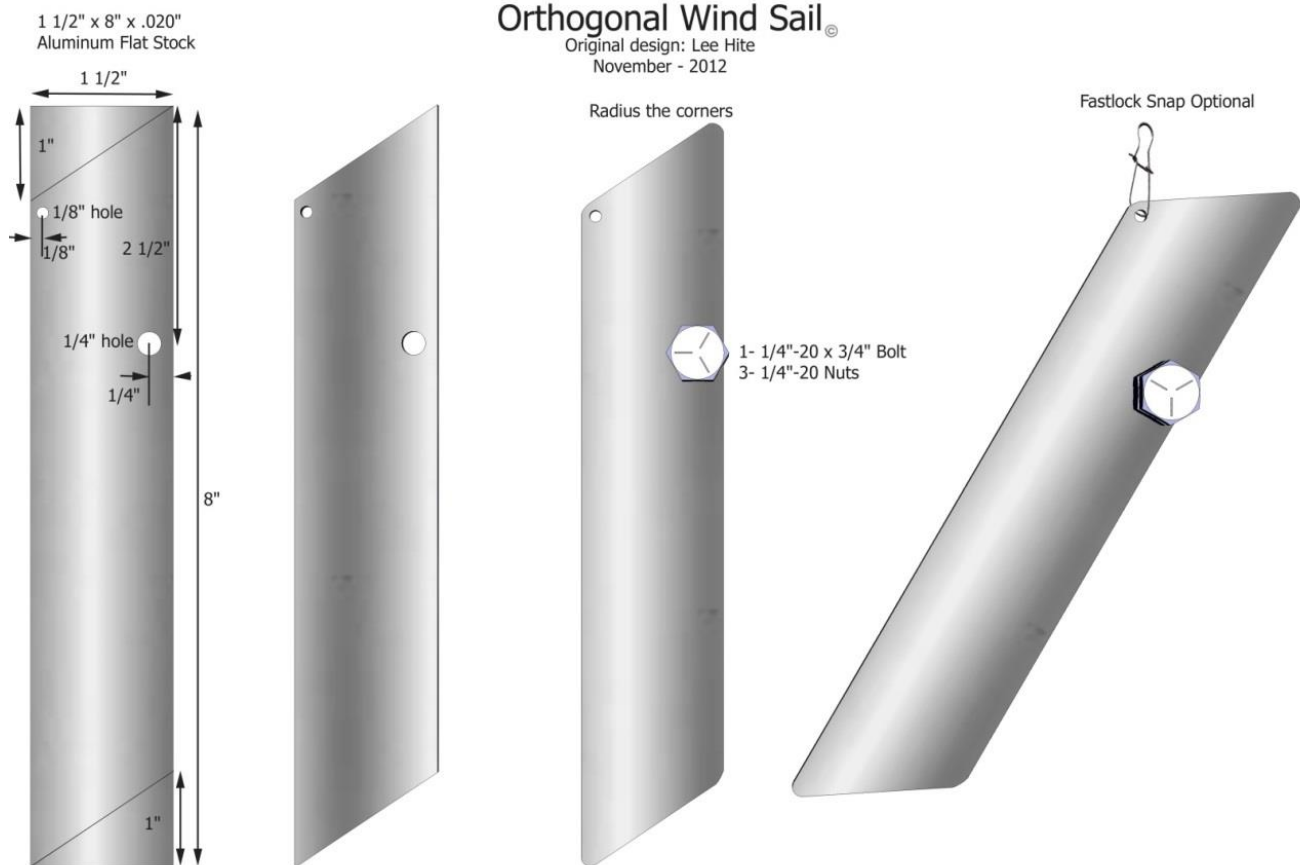

CAUTION !

The orthogonal sail can be dangerous. Do not hang the chime set where the sail can contact children, adults, or animals. The sail makes no noise and can swing a full 180 degrees in a half circle motion. This quiet operation and wide swing can cause people to be unaware of the danger. The sail is flat thin metal and can easily cut the skin or damage an eye as it swings. **BE CAREFUL !**

No Sailing Today: Long and large diameter chimes present a considerable surface area to the wind and can move sufficiently to cause a good strike without the need for a wind sail. In addition, the large diameter striker, often associated with a large chime set, can capture adequate wind for a good strike. Depending on the distance between the striker and the chime tube, not all chime sets require a sail. Pictured right are closely spaced chimes that easily contact the striker with low to moderate winds. Because of the short distance between the striker and the chime tube, the strike is not robust but adequate.

The best solution for you will depend on your type of wind. You may need to try a few different sails for success.



Windless Chimes On occasion there may be times when you want a set of chimes in a windless environment, or even outdoors in a low wind environment, like a heavily wood area. Using an electromagnet to repel a high intensity magnet at the end of the striker rod can provide you with endless possibilities. Typically named a chaos engine, this arrangement can produce a random movement for the striker. Powered by either 120 VAC or a 12 VDC solar charged battery, the electromagnet is controlled by a circuit board with an adjustable strike rate. You can design your individual set of windless chimes using components purchased from [Sonntag Creations](#), formerly Newton's Flying Magnets. Below is a short video demonstrating some of the possibilities.



www.youtube.be/LMAQhuHhdMQ



Tank Bells and Chimes Out of service compressed gas/air cylinders, scuba diving tanks or fire extinguishers are often cut and used as a chime or bell. Based on physical measurements can we pre-determine a musical note for these tanks? To the best of my research I have not found a mathematical method for calculating a musical note for these tanks. Both the neck-end and the base-end seriously alter the vibration performance of the cylinder rendering existing formulas useless.

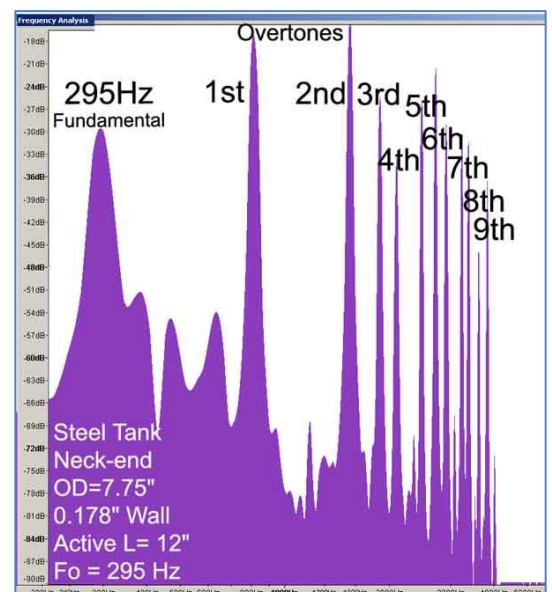

However, once the tank has been cut to your desired length it is easy work to determine the fundamental frequency using an analysis program like [Audacity®](#), . [Other choices work well also](#).

The frequency spectrum does not always follow the traditional overtone pattern for a chime tube and can include a host of additional overtones normally associated with the bell-like sound. See the spectrum diagram to the left.

Energizing all the overtones and avoiding the harsh sound when using a metal striker can be a challenge. A golf ball or baseball can work well but requires a robust strike to properly energize the overtones. I have not had good success using a wood striker unless it's a really robust strike not typically possible with a normal wind sail.

Length Matters or Maybe Not!

A most perplexing situation can exist for some tank lengths. We tested five sets of tank chimes, sets A, B, C, D, and E pictured to the right. All chimes for sets D and E sounded distinctly different and each had a different height, and a different fundamental frequency and overtone structure; however, not true for sets A, B, and C.

In comparison, each chime in set A sounded exactly the same and had nearly identical fundamental frequencies and nearly identical overtones but represented three different lengths. The same was true for sets B and C. There was a slight difference in timbre among the bells, but a considerable difference in length for each set.



Set B has both a neck-end and a base-end chime from a compressed-gas cylinder. While both chimes strike almost the same fundamental frequency (295 Hz vs. 290 Hz), they are of different lengths and have a slightly different timbre but sound mostly the same. Tank B was more melodious than tank A, but not a lot. The difference in overtone structure is pictured to the right.

I investigated circular mode resonance which is a function of just material type, OD and wall thickness and not length, as a possible explanation for this effect. Unfortunately, the circular mode resonance was considerably lower than the observed resonance and offered no correlation to the actual measurements. The calculated vs. observed resonances were as follows:

Set A = 35.4 Hz vs. 133 Hz; Set B = 29.7 Hz vs. 290 Hz; Set C = 71.7 Hz vs. 354 Hz. The formula was provided by Chuck from Chuck's Chimes and is: $F = (T/(2 \cdot D^2)) \cdot \text{SQRT}(E/\text{Density})$

where F = frequency, E = modulus of elasticity, D = mean diameter and T = wall thickness.

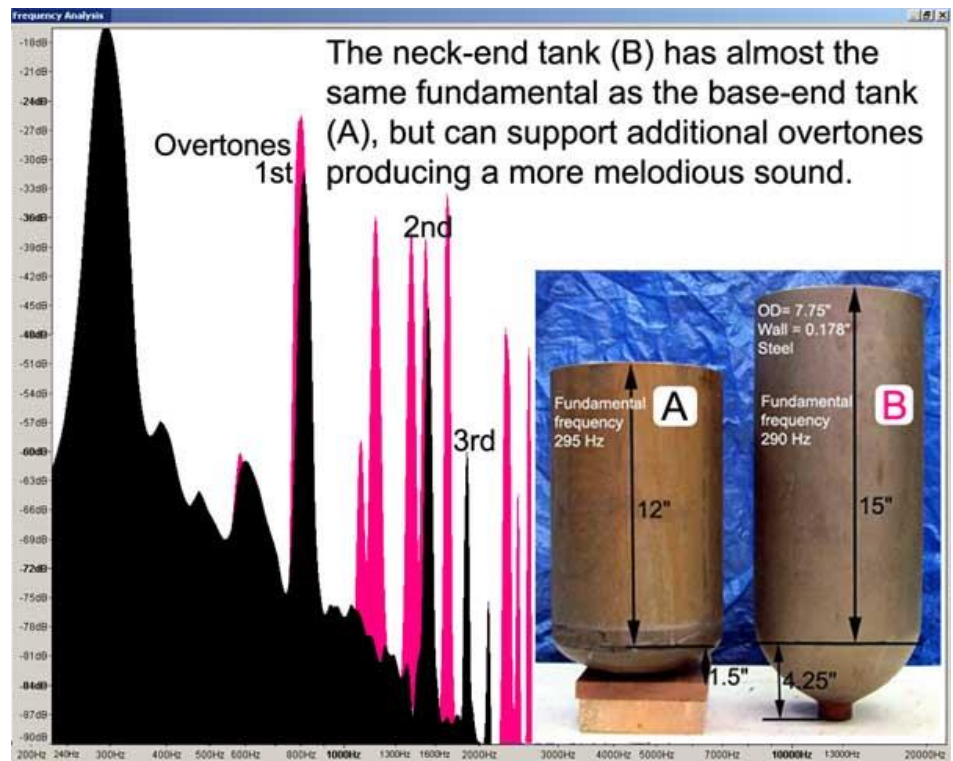

I remain a bit perplexed on exactly why length appears to have little effect on the fundamental frequency and the overtones structure, above some critical length point. Clearly this was not a rigorous scientific test, but enough to cause concern and points to a need for further investigation.

Do not use any formula, table, or chart on the website to predict a tank's musical performance.

Cutting Tanks: If you're new to cutting steel or aluminum tanks and looking for an easy method, I use an abrasive metal cutting saw blade in a radial arm saw, and for small diameter tanks it will work equally well with a cut-off saw, aka chop-saw. The blade pictured right is under \$5.00 at Home Depot. I was pleasantly surprised how easily the blade cut the hardened steel cylinder. The blade also works well for steel or aluminum tubing and rods. Of course, metal cutting band saws and other resources in a welding shop work well



Safety Caution: All these tanks are highly regulated by the US Department of Transportation (DOT), or the National Fire Protection Association (NFPA), or by Transport Canada (TC) and others. Make certain the tank is safe for handling, is completely empty (fill with water and empty to assure all gases are exhausted) and is safe for cutting. Wear all recommended safety equipment including eye protection, hearing protection and respiratory protection. The tanks are heavy and can be dangerous when handling, use caution.

Decorating the Chime

Lightweight coatings The chime tube can be anodized or decorated with a light weight coating such as a thin coat of spray lacquer, spray polyurethane, spray paint, powder coat, crackle/hammered/textured finish (pictured right) without a noticeable reduction in the sustain time. However, avoid thick heavy coats of latex as they seriously reduce the sustain time and can kill the resonance. I suspect a few hand painted flowers from a heavy paint would work okay

Patina finish on steel: Site visitor and artist, Roger Deweese, has successfully applied a metal dye to produce some amazing patina finishes for his tank bell chimes, pictured right. [Read here about the procedure Roger employed.](#)

Patina, the Aged Copper Look: A website visitor sent a procedure to artificially age copper to provide the patina appearance. The procedure works well and pictured on the right are the satisfactory results. I have included the procedure here for your reference. Be patient with this procedure, it can take several days to complete but the results are terrific.

You will need two commonly available chemicals to complete this process. The first is a rust remover that contains phosphoric acid. A couple of sources are Naval Jelly® or Rust Killer™. Secondly, a toilet bowl cleaner that contains either hydrochloric or sulfuric acid. Some choices are Zep® Inc. Toilet Bowl Cleaner, The Works® Toilet Bowl Cleaner, Misty® Bolex 23 Percent Hydrochloric Acid Bowl Cleaner and LIME-A-WAY® Toilet Bowl Cleaner. Read the content labels carefully and look for any brand of rust remover that contains phosphoric acid and a toilet bowl cleaner that has either hydrochloric or sulfuric acid in your local store.

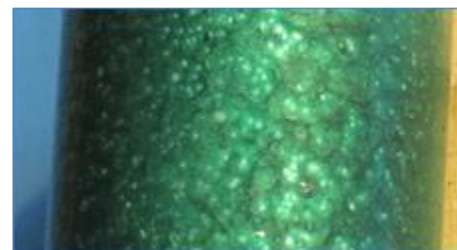

Hammered Paint Finish



Patina Procedure

1. Begin by cutting your chime tubes to length and make any length adjustments necessary for tuning. De-burr and remove any sharp edges from both ends and the support hole.
2. Decide how you are going to support the chime, using either end caps or a support line at the 22.42% location. Attach a temporary line to support the chime vertically. This temporary line will get messy and can be discarded at the end of this procedure.
3. Clean the chime using a soapy solution of dishwashing detergent like Dawn™ or equivalent. I also used a fine grade steel wool to lightly scrub the surface. Dry completely.
4. Hang the chime vertically.
5. Soak a small soft paintbrush or dry rag with the rust remover solution and completely coat the chime. Allow to drip-dry. This could take from a few hours to three days depending on your local humidity. This step slightly etches the surface of the copper in preparation for the next chemical step.
6. When the chime is completely dry remove the dried rust remover from the chime using a dry cloth. Do not use water.
7. Soak a small soft paintbrush or dry rag with the toilet bowl solution and completely coat the chime. This could take from a few hours to a few days depending on your local humidity. A second coat will help to improve the patina look. This step causes the bluish green patina to develop in the etched surface and will darken the smooth surfaces.
8. Allow a few days to dry and the chime should be ready for handling to install the final support lines.
9. The finished chime may not look like the picture above when newly completed. It can take a few weeks to completely darken and turn green in spots. Re-application of the toilet bowl cleaner may be necessary.
10. I have had this patina set of chimes for several years and the patina look gets better every year and holds up well in all kinds of weather.



These are dangerous chemicals. Wear safety glasses, old clothes, rubber gloves and follow all manufactures safety recommendations. If the chemical gets on your skin wash immediately with a liberal amount of water. Use in a well-ventilated area.

Sequence pictures for completing the patina process above.



Cleaned and ready for the process. The tube on the left has been sanded with 150 grit sand paper while the right hand tube has been cleaned with steel wool



First coat of rust remover applied

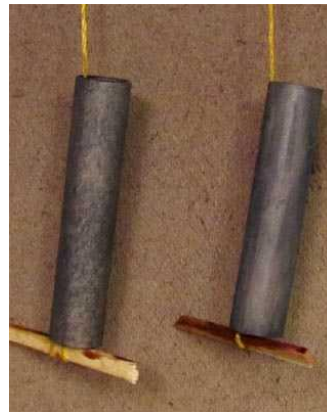

Rust remover dried in two days



Dried rust remover wiped with a rag



First coat of toilet bowl cleaner containing hydrochloric acid has been applied. Dried in about two days



Second coat of toilet bowl cleaner dried. At this stage it does not look like much has happened but be patient, it gets better with time and weather



After a few weeks in the weather



Left hand picture after about two months. Right hand picture after another coat of toilet bowl cleaner



Sparkling Copper: An easy way to obtain the sparkling copper look is to sand the surface of the copper chime using an orbital sander with about 150 grit sand paper. This will completely expose fresh copper and leave behind orbital scratches on the surface. Coat the sanded chime with a clear spray lacquer or a spray polyurethane to preserve the new copper look. See picture on the right.



The Science of Chiming

What is a tubular bell chime? Chimes date to prehistoric times for several cultures, back nearly 5,000 years. Tubular bells chimes were developed in the 1880s when using regular bells in an orchestra setting became impractical. Tubular bells closely imitate church bells and the practice of using a resonant tube as a bell soon flourished and became the traditional orchestra bell.

Traditional church bells or tubular bells can be characterized by their strike note. That bell-like strike note can be expanded to include the overtone structure, sustain time and loudness. That sounds simple enough but imbedded in that explanation are two definitions. The first definition is when a chime, properly designed and constructed, can imitate a bell, and the second definition is that a chime may not imitate a bell. Our objective is to assist you to achieve the most bell-like sound as possible.

Compared to a string or brass musical instrument, designing tubular bell chimes present a unique challenge not experienced elsewhere. Although unique, building a great set of tubular bells can be easily understood and implemented. Ending your project with a successful and pleasing sound is important and setting the right expectations will allow that to happen. The information below may help you to better set realistic expectations.

Loudness Limits: One of the largest differences between a chime and other musical instruments is loudness. Loudness depends on the physical size of the chime i.e. the radiating surface area. Compared to a string instrument where a sounding board is used to amplify the vibration of the string, or compared to a brass instrument that is fitted with a flared tube to amplify the loudness, a chime has no amplifying assistance, other than the inherent surface area of the chime tube. Overall, this loudness limitation for a typically sized chime-set will provide serious limitations for the available range of effective note selection.

On the other hand, if you move up from a typical chime-set, into the really large mega chimes, then good loudness is easily achieved. For example, shown right is a large chime-set from Sandra Bilotto.

Somewhat of an exception is when the resonant frequency of the tube matches the air column resonance for the tube as described by Chuck from Chuck's Chimes. Assistance from the energized air column adds a small amount of loudness.

On the other hand, if you go beyond the size for a typical chime-set into the large mega chime, then loudness is easily achieved. As an example, see the two chimes-sets at the right from the website tama-do.com/product/arche.html

An exception is when the resonant frequency of the tube matches the air column resonance for the tube, as described by Chuck from Chuck's Chimes. Assistance from the energized air column adds a small amount of loudness.



The second limitation for loudness from a tubular chime depends on the location of the selected note on the musical scale, compared to the natural sensitivity of the human ear. Shown right is the loudness sensitivity range vs. frequency for the human ear.

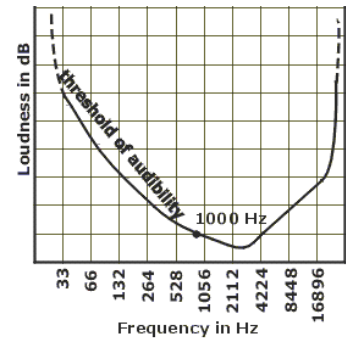

You can see more sensitivity in the range from about 300 Hz to 8 KHz than at other frequencies and helps to explain why we cannot always hear all the overtones, even if they are present. This loudness limitation will have a direct effect on what notes work best for a chime.

Proportional Dimensions: Increasing the chime diameter increases the radiating surface area and contributes to a louder chime but at a cost. The increased diameter greatly increases the length requirement for a specific note, which is not necessarily bad; it just makes the chime set longer as the chime diameter is increased. See the graph to the right for musical note C4.

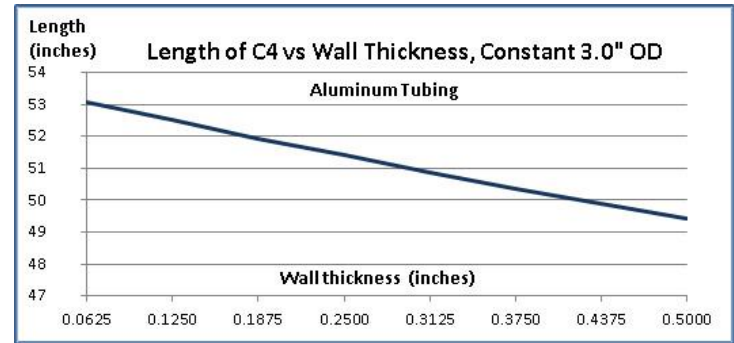

On the other hand, increasing the wall thickness has the opposite effect as an increase in diameter. As the wall thickness increases there is a small decrease in the length requirement for any specific note. In addition, there will be an increase in sustain time from the increased mass. See the graph below.

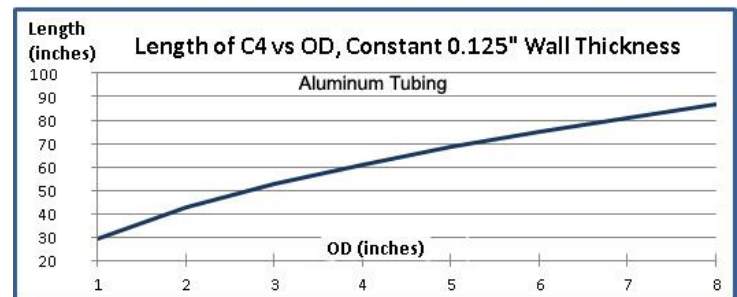

Increasing the outside diameter while keeping the length and wall thickness constant will cause a substantial rise in resonant frequency. See the graph below for Diameter VS. Frequency.

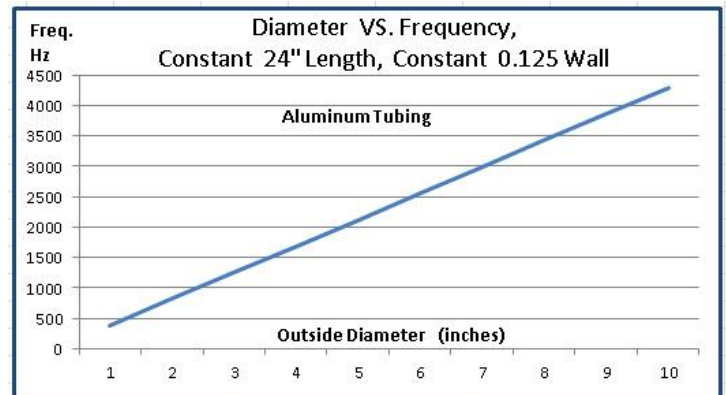

Strike Note vs. Sustaining Note: for a chime, is not an integer harmonic as in string instruments but instead, non-harmonic as in other percussion instruments. When the chime is supported at the fundamental frequency node, see diagram at the right, the higher partials are dampened but the fundamental strike frequency remains. Overtones exist and in a perfect metal where the density and the elasticity are constant, have theoretical multiples of the fundamental multiplied by X 2.76, X 5.40, X 8.93, X 13.34, X 18.64 and X 31.87.

However, in the real world of metal tubing that does not have a consistent density or elasticity, the multiples will drift from the theoretical values either up or down by as much as +2% to -8%.

If we could hear the complete compliment of all overtones for each note of a chime tube, it would be a most wonderful bell-like sound.

Unfortunately, not all of the fundamental tones and/or all of the overtones can be adequately radiated as an audible sound by the chime tube, for all possible lengths of a chime. This condition also limits the available range of notes that have a bell-like sound.

Unfortunately, not all the fundamental tones and/or all of the overtones can be adequately radiated as an audible sound by the chime tube for all possible lengths of a chime. This condition also limits the available range of notes that have a bell-like sound.

For example, a chime cut for C2 (65.4 Hz), the fundamental frequency is audibly absent, aka the missing fundamental, along with little audible contribution from the first overtone (180.5 Hz). The remaining overtones combine to produce a perceived musical note. The perceived note does not coincide with any specific overtone and is difficult to measure without a frequency spectrum analyzer or perhaps a good musical ear. The good news is that the brain processes the information present in the overtones to calculate the fundamental frequency, using fuzzy logic.

You can see from the display at the right that a chime cut for 272.5 Hz (near C4#), has two characteristics. The first characteristic is the sound when the chime is first struck, the Strike Note. It comprises both the fundamental and the first four overtones and has that traditional chime sound for a short period of time.

The 1st overtone contributes for about two seconds and rapidly deteriorates. The remaining sound is solely the fundamental strike frequency. Note the long sustain time for the fundamental.

The 2nd, 3rd and 4th overtones are present and contribute to the strike note but attenuate quickly. They have little contribution to the lingering perceived sound, aka sustain time or hang-time

In contrast to the above example, the sound for a chime cut at fundamental C6 (1046.5 Hz) and above is mostly the fundamental and the overtones are audibly absent or mostly absent.

In addition to the many overtones that may be present for a chime we have the difficulty of knowing which overtones are prominent for each note, because of the ear's sensitivity as represented by the equal loudness curve. As you might suspect, the loudness of a particular overtone changes as we move up the scale. For a typical ear sensitivity range of 300 Hz to 3 KHz, see the data audible fundamental and overtones for wind chime notes as a simple example for the range of audible fundamental frequencies and overtones. Obviously, this is not the entire audible range of the ear but is presented as a simple example of the limited ability of the ear to hear all the frequencies generated by the overtone

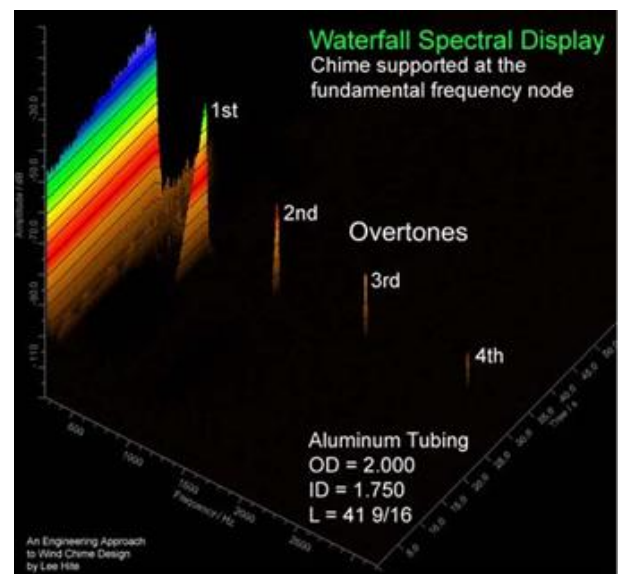
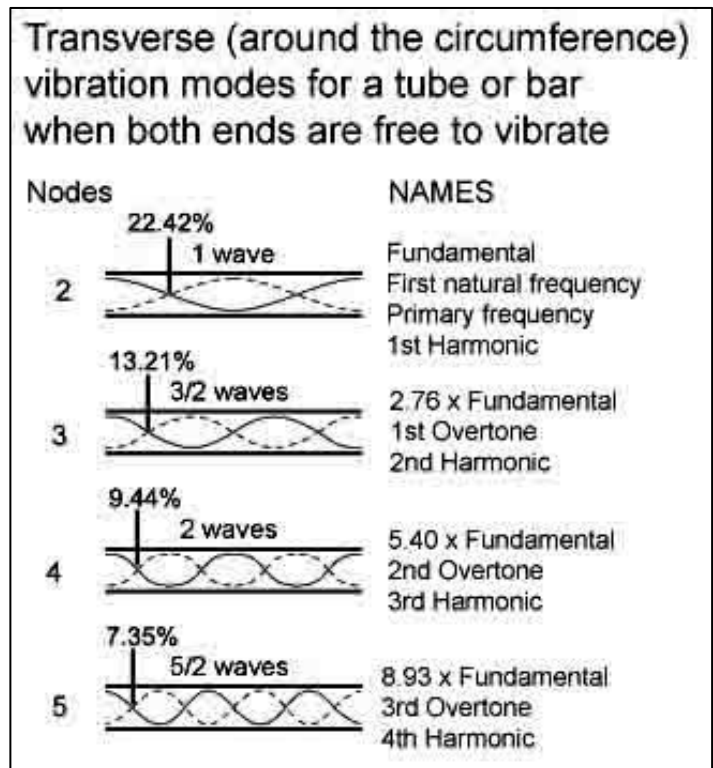

Waterfall spectral display for a chime supported at the fundamental frequency node

structure. In particular, the range of C2 to C3 contain many audible overtones while the range of C5 to C7 contains very few. The notes from C2 thru C4 produce the most melodious sounds, most bell-like, and are easy to build. Precise tuning is not required unless the set is for an orchestra setting.

The Missing Fundamental is when the brain uses “fuzzy logic” to processes the information present in the overtones to calculate the missing fundamental frequency.

To gain a better understanding of the perceived note I examined a set of orchestra grade chimes manufactured by a UK manufacture. The set was 1.5 inch chrome plated brass with a wall thickness of .0625 inches and ranged from C5 (523.30 Hz) to G6 (1568.00 Hz). The length of C5 was 62 5/8 inches. The fundamental frequency for this length is around 65 Hz, about C2# yet the perceived note is C5 at 523 Hz. The fundamental strike frequency of 65 Hz and the first overtone at 179.4 Hz ($65 \times 2.76 = 179.4$ Hz) are audibly absent, aka the missing fundamental. In fact, even the second overtone at 351 Hz will not be strong in loudness. The remaining overtones (mechanical vibration modes) combined to produce what the ear hears acoustically, which is C5 at 523 Hz, yet there is not a specific fundamental or overtone at that exact frequency.

I spoke with the people at a major USA chime manufacture for symphony grade instruments and confirmed that indeed the process of tuning an orchestra grade chime is a complex process and understandably a closely held trade secret. The process involves the accounting for all frequencies from the fundamental (whether present or missing) through the many overtones, by the use of math calculations, acoustic measurements, and the careful grinding of the chime to achieve the correct length for the desired note.

An orchestra chime is not supported by the classical wind chime method using a string through the chime at the first frequency node 22.4%, but instead, is fitted with an end cap that contains a small top hole through which a steel cable supports the chime. From testing I find that the end cap not only enhances the bell-like sound, by increasing the duration of the first overtone, but it also lowers the fundamental frequency by about 4% to 12 % from calculated values, depending on tube material and diameter.

More on this in [chime tube mechanical support](#). Many have spent time investigating the missing fundamental and the perceived note from a chime. Some good sources are: [Hyper Physics](#), [Wind Chime Physics](#), and [Wikipedia](#).

A Bell-like Chime: Using the above characteristics for a chime, I found a limited set of notes that will produce a bell-like sound from a tubular chime. Using the musical scale as a reference, they fall into three categories as follows:

The 1st chime category:

(Most bell-like) has a note range from about C2 to the C4 octave. The fundamental strike frequency is present but audibly absent (the missing fundamental) and there are a host of well-pronounced overtones. Often the first overtone can also be inaudible. The perceived sound is not the

fundamental strike frequency and not the overtones, but an imaginary note created by the combination of the overtones. To the ear this is a very melodious sound and clearly a bell-like sounding chime. The larger physical size of this chime for this note range causes the loudness to be quite adequate, and

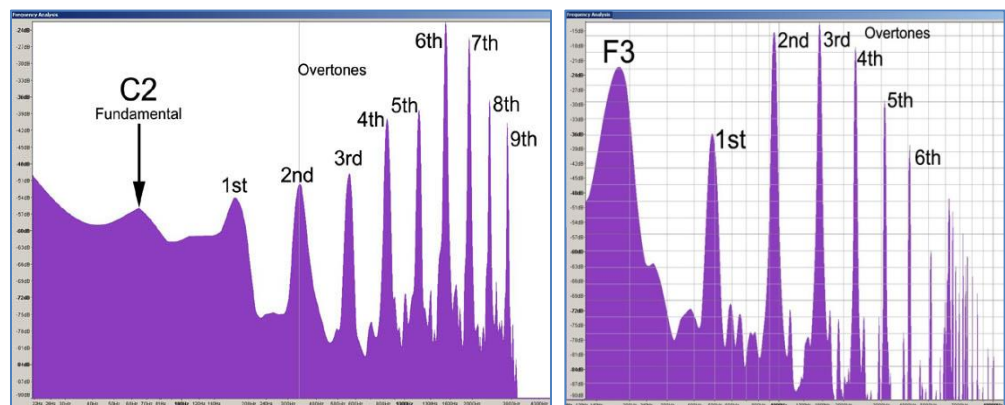

easily supports radiation for the many overtones. Note in the spectrum displays below, as we move up the musical scale the overtone contribution becomes less and less.

The 2nd chime category: (Almost bell-like) has a note range from about C4 through most of the C6 octave. The fundamental strike frequency is mostly audible, and some overtones contribute to the perceived sound. The perceived note is not the fundamental strike frequency and not the overtones, but a combination of both that produce a perceived musical note. The sound can be acceptable but may not be the sound you are looking for. This has an almost bell-like sound and can sound fairly good, but not particularly melodious. The loudness is acceptable but not great.

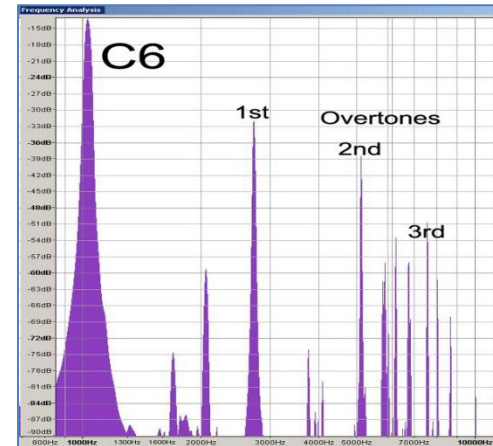

The 3rd chime category: (Non bell-like) has a note range from about C6 through the C8 octave. Not unlike other percussion instruments this category is characterized by an audible fundamental strike frequency (a noticeable pure tone) with overtones mostly absent. Overtones have minimal contribution to the perceived musical note. This note range may not be particularly pleasing to the ear but should not be ignored as a pure tone and is definitely a non-bell sounding chime. In addition, the loudness is typically low caused by the short length of the chime causing a low radiating surface for the higher notes. The rapid attenuation of high frequencies in the environment causes this note range to quickly diminish at a distance.

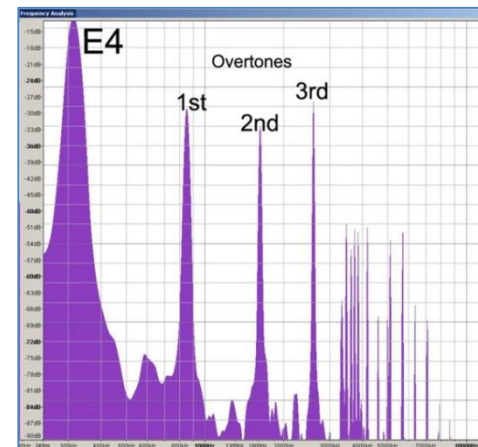

Conclusions: Clearly there is more to a chime than I had anticipated and I am sure I have not learned all that there is to know about the physics of a chime. This was originally a Christmas present for my daughters and not a focused research project. I am convinced that it is not necessary to hand tune a set of bell-like chimes designed for musical notes from fundamental C2 through C4 because the formula achieved the desired frequency well within 1 Hz. Tuning to achieve an accuracy closer than 1 Hz was a waste of time. However, for a fundamental note from C5 and up, good tuning is required. Good physical measurements are important to achieve the calculated accuracy.

My favorite design has changed over the years and is currently an end cap supported chime with the striker contacting the tube at the very bottom of the chime using either a tapered striker or a star striker, and having the wind rotate the chime set using a single line support for the support disk. Unfortunately, I know of no formula for calculating the length of a chime tube with an end cap. I begin with a length from standard calculations on this page and then tune by trimming off the length. End caps lower the frequency by as much as 8% to 15%, which requires removal of material to increase the tuning back to the correct value. Yes, it is a lot of work if you want exact tuning for a tapered end!

On occasion I have added an end cap to the calculated value for an open-end tube to gain a more bell-like sound, but not adjusted the length to regain accurate tuning. For the most part, it has been difficult to acoustically tell the difference between the un-tuned chime set with an end caps and a set of tuned chimes without end caps. Perhaps I have been lucky or maybe the natural shift caused by the end cap is consistent for all five tubes, and they remain mostly in tune.

Your wind (single-direction or turbulent) and wind speed will determine the best choice for both the wind sail and for the chime striker. Rotating the chime-set works well to solve the dingdong sound caused from low velocity single directions winds.

Another phenomenon we observed, but did not have time to investigate, was the simultaneous production of sound from the natural bending mode of the chime coinciding with the resonance of the air column for the tube. The good news is that another engineer, Chuck at Chuck's Chimes, has done an excellent job detailing this affect, I suggest you give this a look-see. He has excellent information and calculations to accomplish this special effect. www.sites.google.com/site/chuckchimes/home

Frequently Asked Questions: FAQs

Question: We do not often have a lot of wind here so a design that does not need a lot of wind is important. Somebody gave me a cheap little metal commercial set and it basically never made any sound because there is rarely a stiff breeze. What are your thoughts about this?

Answer: The force from the wind is cube law, meaning for a doubling of wind speed produces nine times more force acting on the chime. So little changes in the design can have a big effect on the sound. The best advice I can give regarding spacing of the chime elements for low wind, high wind, etc. is experimentation. Every special design I have done for myself and with other artist has never been a standard design. As such, I continually must build several prototypes where we change the spacing vertically and, in your case, horizontally. Most of my discoveries about chimes have been from many failures. On the surface, chimes seem incredibly simple, but the trick is implementation.

Question: I wanted to make a rod based wind chime twice as big the pre-calculated numbers, could I multiply the pre-calculated numbers by two (to get double the length) and still have the same tones as the pre-calculated numbers describe, only a bit deeper?

Answer: You're almost there but not quite. The relationship is not linear, but there is an easy way to do this.

Say for example, you had a one inch steel rod and you want to go lower than the attached table will allow, i.e. below 32.7 Hz.

Begin on the Metal Rod Length Calculator sheet in the calculator and enter the type of metal the rod diameter, one inch, steel.

From there you will notice the lowest is 32.7 Hz with a length of 74 3/16 inches.

Then go to the next sheet, Metal Rod Ratio Calculator. See chart below.

Enter what you know, i.e. 74 3/16 inches or 74.19 and the frequency 32.7 Hz.

And the desired frequency (Half of the original) 16.35 Hz.

The result will be a length of 104 15/16 inches long with a hang point of 23 1/2 inches.

Repeat this procedure for each note you wish to lower.

Resonant Metal Rod Length Ratio Calculator				
Can be used for a Metal Rod unrestricted at both ends by referencing a rod of known length & frequency.				
Enter Values in Blue Boxes			Answers in Green Boxes	
Enter	Enter	Enter	Answer	Answer
measured Rod length	measured Rod frequency	desired Rod frequency	length of Rod for desired frequency	Hang point for Rod open at both ends
mm or Inches	Hz	Hz		
74.19	32.7	16.35	104 15/16	23 1/2

Question: What is the best line to re-string a chime set? I have about 20 chimes that use a cheap support cord and the line breaks after a few years. I need to re-string them and do not want to have to keep doing that. I need something sturdier.

Answer: My all-time favorite to withstand the weather elements is light weight chain found in hobby stores and occasional at the local home improvement stores. Depending on the weight of the chime tube my second choice is 80-pound braided fishing line. Make sure to deburr the support holes smooth.

Question: Should I start at C3 or C5, I was fortunate in coming across a 20' section of 1.625 OD x 1.375 ID aluminum pipe. According to your spreadsheet calculations I've got just enough to make the C-9 chord starting with C3. In reading your info I see that some of the lower frequencies may not be heard more than a few inches away. Given the size of this pipe do you think we'll be able to hear the C3 or might we be better off making two shorter sets starting with C5? The thought of the longer pipe set seems really neat!

Answer: As long as you have enough to begin at C3, by all means start there. You won't hear much of C3 but the other notes will be more melodious and bell like. I often start there or C2, depending on the physical limitations for mounting and the intended application.

Question: Chakra healing chimes: I am using 3-inch OD by 1/4-inch wall aluminum tubing. I found a supply at the local scrap yard but do not know its alloy. Upon hanging an 8 ft. length from my workshop ceiling and striking it with various beaters I was amazed at its tone and strength of vibration. Could you help me determine the lengths required to build a set of Chakra healing / vibrational chimes consisting of 7 chimes? There are 7 notes / frequencies I wish to reproduce corresponding to the individual Chakra 's frequency; 396 Hz, 417 Hz, 528 Hz, 639 Hz, 741 Hz, 852 Hz, 936 Hz and an eight option is 432 Hz.

Answer: Sure, just us the regular calculator for A=440 Hz, enter the OD, ID and type of metal then find the chakra frequencies in the frequency column. If the calculator does not have your specific frequency, go to the bottom of the calculator and use the generic blue colored entry calculator where you can enter a frequency and find the length and hang point, or enter a length and find its frequency and hang point. See picture below.

Calculate Length or Frequency for ID & OD entered above					
Enter F=	220.00	45 9/16	10 3/16	1157.3	259.5
		Enter L ↓			
F=	981.96	21 9/16	4 13/16	547.7	122.8

Question: Can I use nickel-silver tubing? Is there a way to calculate the hang points based on your tables? ID on one tube is 0.5 inch, the other 2 are 5/8 inch. My son, in the marching band, believes his trombone is a weapon of mass destruction. After 3 rebuilds, I have tubing from the leftover parts that I wish to turn into a wind chime. I asked the mechanic about the composition of the tubing (brass or ?) and he said it was nickel-silver. Sure enough, it has a pleasant high-pitched ring despite the long (30 inch) length. However, the hang points do not seem to correspond to the brass or aluminum columns in your table.

Answer: Only two issues effect the sound from one metal to another, density and elasticity. So, the density of nickel-silver is 0.31 Lbm / in³ and the elasticity is 18,500,000 psi. You can see from the chart at the right, nickel-silver is close to copper. I would suggest using the copper charts for the pre-calculated measurements or use copper in the DIY calculator. The most important measurement is to hang the chime at the 22.4% point.

Material	Material Properties	
	Modulus of Elasticity	Density
	psi	Lbm / in ³
Aluminum	10,000,000	0.0980
Brass	17,000,000	0.3080
Cast Iron	13,400,000	0.2600
Copper	16,000,000	0.3226
Steel	30,000,000	0.2835
Stainless Steel	28,300,000	0.2830
Titanium	14900000	0.163

On the data page you can enter the actual density and elasticity to produce an exact calculation

Question: [Can I mix sizes and metals?](#)

Answer: Yes, you can mix sizes within a given metal and you can mix metals. Make sure you use the correct chart or calculator settings for each size, wall thickness and type of metal. Best to experiment with different metals because some combinations sound wonderful and other not so good.

Question: [Wondering why these tubes sound better when](#) the striker is placed an inch below center on the shortest tube with the tops all the same height? When the striker is placed an inch below the center of the longest the short tube has little to no sound?

Answer: We want to avoid exact dead center for any chime and when they are center aligned that is an easy task. But when they are top or bottom aligned the striker can inadvertently come close to dead center for one of the chimes. Because chime length is not a linear relationship as we move up and down the musical scale, exact placement of the striker for every chime set is slightly different. You did the right thing by experimenting to find the best sound. On most every set, I generally adjust the striker higher or lower to achieve the best sound from every chime.

Question: [D:\DATA\A My](#)

[Webs\LeeHite.org\chime_pic\bar_chimes.jpg](#) I am working on a Mark Tree chime set (bar chimes, used by percussionists and drummers, pictured right). I checked on the commercial ones and they all use the same hang point on the bars. It may be because it is cheaper and quicker to make them this way and they look good, but will not sound as good as the 22.4% hanging point method? I'd like to hear your opinion about this topic!

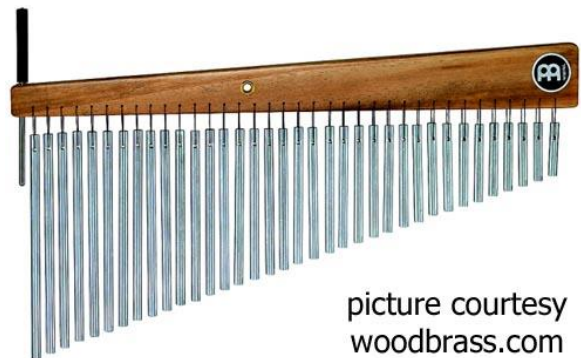

picture courtesy woodbrass.com

Answer: A bar or chime can be supported at any point along its length and will ring when struck, but not well. Good sustain time and rich contribution from the overtones, that produce the bell-like sound, can only occur when supported at the 22.4% location. All bars in the set pictured here will sound distinctly different from each other but will not yield the bell-like sound because of improper mounting. As a footnote, my neighbor (a very practical engineer) built a xylophone and did some experimenting with support points for the bars. His choice was 22% from each end because

that location provided the best sustain time and the best sound. I completely agree with his findings (22.4%).

Question: Is there a length where a tube of a given size will not resonant as intended?

Specifically, I cut a tube of 1.5-inch thinwall steel conduit to 1002 mm, and it sounds higher in pitch than an adjacent 730 mm tube, which should sound higher. I just cannot wrap my head around this.

Answer: You discovered part of the missing fundamental phenomena. The chime tube appears not to resonant at the design frequency, but it does resonate. The 1002 mm length has a fundamental resonance of about 193 Hz and that frequency is difficult to hear because of the low sensitivity of the ear at the lower frequencies (mostly below 300 Hz). Therefore, you will hear the second overtone better which is $193 \text{ Hz} \times 2.76 = 523 \text{ Hz}$. The fundamental for the 730 mm chime is about 384 Hz which is getting more into the sensitive range of the ear and you are much more likely to hear it's fundamental as compared to the fundamental for the 1002 mm chime.

Question: Does a coating (powder coat, anodize or paint) affect the tone quality, tuning, or sustain time of the pipe?

Some chimes are anodized or appear to have a clear coat type finish for weather resistance or aesthetics I assume.

Answer: In general, the answer is no. However, if you were to apply a thick latex paint type coating, the extra mass would have a noticeable effect, perhaps to the point of killing resonance. However, a thin powder coat or anodizing will have no effect on the design frequency or sustain time.

Question: Can I use anodized aluminum and is it expensive?

I recently came across your website as I researched the idea of building a set of wind chimes for my wife for our anniversary. I spent several hours reading your website and have found more than enough step by step info on how to do what I want to do. You absolutely answered every question I had and sever

Answer: There is no difference in the sound created using either power coated or anodized metal. The only slight exception is if there is a heavy clear coat over the power coat. A light coat is okay. A heavy coat slightly reduces the sustain time, but not much.

Cost wise I do not have much experience here. I have seen very reasonably priced anodized aluminum on the internet, nearly the cost of un-anodized. If you are buying tubing already power coated, as opposed to having it done in a custom shop, I would not expect it to be expensive.

Question: Do you have a Phone app to calculate chime lengths?

Answer: I do not but site visitor Andrew Hughes has an [Android Version](#) in the Google Play store.

Question: The hang point is usually close but far from exact on chimes I have measured. Should you drill the hang point hole at the center of the calculated measurement or is the hang point where the string contacts the tube (upper edge of the hole)?

Answer: The location for small holes, 1/8 inch or less, can be exactly on the mark. However, holes larger than 1/8 inch (particularly 1/4 inch and larger) should be positioned, as you suggest, so the upper edge of the hole is where the support line touches the chime.

Question: Does the hole size that you drill for the hang point matter?

Answer: Yes, if the hole is large, relative to the diameter of the tube, it can affect the design frequency, but a small hole has no effect. I personally use 1/8 inch for many of the chimes .If you need a hole larger than 1/8 inch, position it so upper edge of the hole in on the hang point mark.

Question: Chimes not Chiming!

I recently bought two, not cheap, wind chimes – and they do not chime in the absence of hurricane gale winds! Is there anything we can do to get them to catch any breeze that happens by? Would the CD section in your article be all he needs? I have spent a long time on the internet looking for some quick fix but cannot find anything. The power company recently cut down all the shrubs we have been carefully tending for years and now we have dreadful road noise. The chimes were an optimistic detraction to that new situation.

Answer: Yes, there are several options. You describe a common condition where the sail is either too small or too heavy to supply a good jerk to the striker. Without seeing the set of chimes directly, I might suggest you replace the wind sail with something larger and lighter weight. As a test, I use an old CD for a temporary sail, just to make the point that it needs to be light weight and large. Often an old CD is not large enough. You can use anything that pleases your eye that meets the size and light weight requirements from your testing.

Question: Chimes for extremely high winds:

When I say extreme, I mean regularly 150 km/hr (92 MPH) and occasionally up to 225 km/hr (140 MPH).

My solution is twofold; first, place the chime set on the opposite side building from where the high winds originate. However, on that side we still get 60 MPH winds several times a year. Secondly, use very heavy pipe. I found some rusty 2-inch pipe with 1/8-inch walls and cut a set for C4. Unfortunately, it was not long enough for a C3, which I wanted. Problem: It's so heavy that it's tough to get much volume out of it, but it will resonates for ever.

Do I want a hard strike with a hockey puck? My current plan. I also want to add in a 'star' type of thing to add some light tones and to contain the striker inside the chimes.

Answer: Yes indeed, with a heavy pipe like that you need a robust strike as you already suggest. If a hockey puck is inadequate, try a scrap piece of treated lumber. If that is inadequate try hard maple or oak. Also, the size of the wind sail is important here. Try different sizes until you achieve the sound you want.

A star striker should work well in those high winds to assist in keeping everything aligned, but in those extreme winds they will probably escape the star. You may need to thread a 50# fishing line around the outside tips of the star to keep the tubes from escaping and getting all mixed up. Drill a small horizontal hole at the tips for the monofilament line.

Question: Where do I get mounting pins, what size is recommended and how are they held in position?

Answer: I typically use 1/8 inch brass tubing that can be found at my local hobby store (where a person can buy model airplane parts, model trains, model cars and the like) and occasionally at home improvement stores like Home Depot, Lowe's, Menards, etc.

If you insert a 1/8 inch rod or tube into a 1/8 inch hole, it can be loose. Use a ball-peen hammer to slightly flatten each end of the pin, for a force fit, or use a spot of glue. With copper chimes, the pin can be soldered. Then, file off the excess, leaving little to no evidence of the pin.

Question: How does the string stay in the middle of the pin so not to slide off to one side?

Answer: A spot of super glue, hot glue or epoxy will do the trick. A knot also works well.

Question: Is it possible to support a chime in a way that it is fixed, for example with a nail, without losing its tune? Also is it possible to support it so I will not need to drill a hole? I would like to build a music box that uses a chime tube.

<D:\DATA\A My>

Webs\LeeHite.org\chime_pic\Noninvasive_chime_support.jpg

Answer: Yes, the chime can be structured for a fixed support using several methods. Any method should locate the support at 22.4% from both ends.



The noninvasive method uses the traditional one wrap string method for supporting an orchestra grade chime or bar, as shown right, courtesy of Woodstock Chimes. Located above or below the chime, either method works equally well.

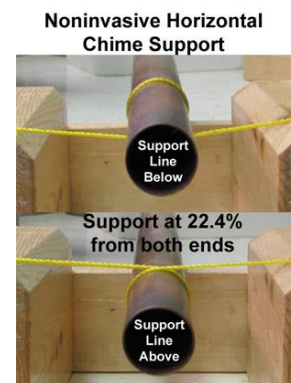

An invasive and more rugged mount can be from a stud on one or both sides of the mounting location as shown right. A locking nut on the outside of the chime will secure the stud in place and allow attachment to the supporting structure, as often found in playground chimes. I would avoid inserting a bolt through the chime tube, because tightening nuts on both sides can stress the tube causing it not to resonate or reduce the sustain time.

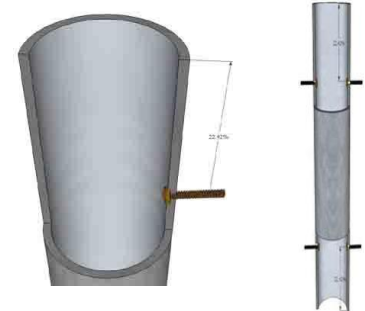

Question: How do I attach the support line to the support pin when the pin is down in the tube?

I plan to make a chime set using 2-inch steel electrical conduit. The largest chime would have a hang point of 9 5/8 inches from the top. How do I get the line around the pin when it is 9 5/8 inches from the top?

Answer: Hold the tube horizontal with the support pin also horizontal. Tilt the tube to be mostly vertical, but not quite. Feed the line down the tube on the bottom side, passing one side of the pin and out the other end. You may need to attach a small weight to the end of the line, like a pinch-on fishing line sinker, to provide sufficient weight so the line will feed all the way through. You can also blow on the tube or use compressed air to force the line out the other end.



Next, rotate the tube 180 degrees and starting from the other end, feed the line back down the tube, passing the opposite side of the pin. Pull both ends of the line up to the pin from the top end and tie a slip knot. Pull the knot taught around the pin as shown to the right. You may need to adjust the line to be in the center of the pin using a coat hanger wire or other handy utensil.

It may be difficult to see inside a dark tube. Place a white paper on the floor and hold the tube above the paper as you peer into the tube. This generally allows enough light in to see the location for the line centered on the pin.

Question: I want to use a tapered striker for (6) 2-inch chimes, and the calculated striker size is 3.25 inch, would that be the top or the bottom diameter?

Answer: That should be the largest diameter, i.e. bottom diameter if tapered or center diameter if bullet nose.



Question: Best striker shape and weight for large tubes?

My son gave me 3 stainless tubes. They have a diameter of 6 inches and between 5-6 feet long. In a way, my chimes will be similar to the ones on your site from Craig Hewison, except he has 5 chimes where I have 3. This means the spacing for my chimes will be greater. My plan is to line up the bottoms of the chimes. My thought is to use a circular wooden disk of either the tapered edge or knife edge or straight edge design. I would say my home area has light to moderate winds, for the most part. Do you have comments on these 3 designs?

Answer: My preference is a bullet nose edge for large tubes. Heavy chimes need a robust strike and a rounded edge striker last longer and can be simple to fabricate. Regarding the weight, I would start with a 1.5-inch-thick section of treated lumber, not any thicker, $\frac{3}{4}$ inch could work. There is a close relationship between a striker's weight and the ability of the sail to adequately jerk the striker. Because of that relationship, I cannot suggest an exact weight, but I do suggest experimentation. I often find myself making two or three strikers before I am satisfied with the overall performance from both the striker and the sail.

Using three tubes, I would not suggest the orthogonal sail. Once that sail get to swinging, it can depart a lot of energy and I am concerned that would cause the striker to escape to the outside of the set, not all bad, but it can be a nuisance. I often need to experiment with two or three strikers and sails to achieve the desired sound. The good news is the sail can be larger than normal because a large sail does not look so big next to large chimes.

Question: I want deep bass chimes that are resonate.

I saw somewhere on the site a casual comment about a chime not hitting C2. Did I misunderstand? I want to buy some 2-inch EMT and tune them in a Hirajoshi scale at C2 E F# G and B. But, that's \$75 worth of EMT I will be hacking up. Do you think it will work? I just want a deep bass set of chimes and I am hoping 2-inch EMT of 66 to 9 inches (using your EMT table) will get me something deep and resonant. Any advice?

Answer: Another excellent question and you read correctly. The chime will produce the C2 note at 65.4 Hz, no problem, but the ear will not hear it? To hear 65.4 Hz, we need to move a lot of air, thus the need for woofers used in sound systems. If you place your ear about two inches from the long tube, WOW, you hear the 65.4 Hz, it's actually there. But, back up two feet and you won't hear it.

What you hear is a chime note missing both the fundamental (65.4 Hz) and the first overtone (180 Hz). You hear the remaining overtones.

So, what to do? You can still make the long tubes cut for the C2 octave. The larger size will enhance the overtones (second overtone, 353 Hz and up) and you will hear lower notes than without long tubes, but it will not be the actual C2 note. If you happen to have a small public address amplifier and microphone, place the microphone about an inch from the tube. Wow! C2 is present, but it needs amplification to be audible.

Question: Does the diameter of the support pin effect y the chime sound? I am using 2-inch tubing and the brass support rod I am considering is 1/4 inch in diameter, so quite substantial. Trying to use what I have during virus lockdown.

Answer: A 2-inch (55 mm) tube with a 1/4-inch support rod should be fine. I would not recommend it for a smaller tube like 1-inch OD. normally have not used that larger size and prefer 1/8 inch or slightly less. Just make sure it's snug and cannot rattle or work loose.

Question: I saw **chimes on a tropical island made from sticks of coral**. (worn staghorn coral on the beach, which was there by the millions of tons due to hurricanes.) So, I brought back a bunch of sticks of coral. But trying to get maximum wind chime effect is hard, especially on the first try. The coral is much heavier than metal, but it does have a sort of ceramic waterford ring to it. I cannot find any specific plans, but I was leaning towards orienting many of the pieces horizontally for maximum instability and strikes. I also wanted to stay with natural materials and make the top support out of maybe two longer pieces of coral in an X configuration.

Answer: My first attempt would be to carefully measure down from each end 22.4% (.224) and tie a monofilament fishing line or perhaps a braided fishing line at those points for support, then test their sound by carefully striking the coral with a hard rubber mallet. I have no experience with coral chimes, but they should follow the basic laws of physics. They will probably need a robust striker because of their small size, depending on how easily they break.

Question: I use your calculator for calculations but what I do not understand is when I use smaller diameter pipes the suggested length is also shorter. **Shouldn't smaller pipes produce a higher pitch?** Below is an example: the first is with diameter 80 mm. Here it suggested the lowest pipe is 974.7 mm.

OD mm = 80,000		ID mm = 78,000		Metal = Stainless Steel < Click to Select							
Wall = 1,000 mm		Length calculated for fundamental F Hang Point is for fundamental F node									
Note	Freq Hz	Length inches	Hang Point	Length mm	Hang Point	Note	Freq Hz	Length inches	Hang Point	Length mm	Hang Point
C1	32,70	153 7/16	34 3/8	3897,3	873,8	C5	523,30	38 3/8	8 5/8	974,7	218,5
E	41,21	136 11/16	30 5/8	3471,9	778,4	E	659,30	34 3/16	7 11/16	688,4	194,7
G	49,00	125 5/16	28 1/8	3182,9	713,6	G	784,00	31 5/16	7	795,3	178,3
A [#] /B ^b	58,30	114 7/8	25 3/4	2917,8	654,2	A [#] /B ^b	932,30	28 3/4	6 7/16	730,3	163,7
D2	73,41	102 3/8	22 15/16	2600,3	583,0	D6	1.174,61	25 5/8	5 3/4	650,9	145,9

When I change the diameter to 40 mm, I only need a pipe of 684.2 mm for the C5 note.

OD mm = 40,000		ID mm = 38,000		Metal = Stainless Steel < Click to Select							
Wall = 1,000 mm		Length calculated for fundamental F Hang Point is for fundamental F node									
Note	Freq Hz	Length inches	Hang Point	Length mm	Hang Point	Note	Freq Hz	Length inches	Hang Point	Length mm	Hang Point
C1	32,70	107 13/16	24 3/16	2738,4	614,0	C5	523,30	26 15/16	6 1/16	684,2	153,4
E	41,21	96 1/16	21 9/16	2440,0	547,0	E	659,30	24	5 3/8	609,0	136,7
G	49,00	88 1/16	19 3/4	2236,8	501,5	G	784,00	22	4 15/16	558,8	125,3
A [#] /B ^b	58,30	80 3/4	18 1/8	2051,1	459,8	A [#] /B ^b	932,30	20 3/16	4 1/2	512,8	115,0
D2	73,41	71 15/16	16 1/8	1827,2	409,7	D6	1.174,61	18	4 1/16	457,2	102,5

In my opinion, the pitch should be going up when I use smaller pipes, but that does not correspond to your chart. Can you help me to understand the suggested lengths?

Answer: welcome to the complicated world of circular resonance. This is best explained with some info from the website under the section for proportional dimensions. Increasing the chime diameter increases the radiating surface area and contributes to a louder chime but at a cost. The increased diameter greatly increases the length requirement for a specific note, which is not necessarily bad; it just makes the chime set longer as the chime diameter is increased. See the graph below for musical note C4.

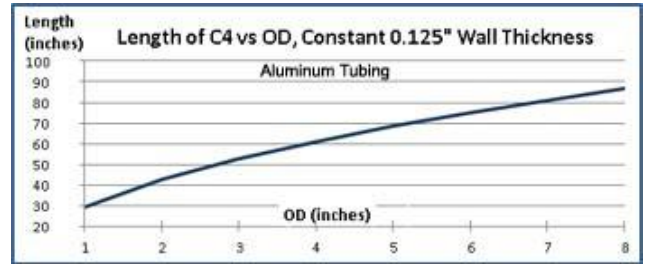

In your case, decreasing the diameter considerably shortens the length for a given note. Your observations are correct and perfectly normal.



Appendix A - The math

I am not aware of calculations for a tube closed at one end, i.e. a chime with an end cap.

The bending natural frequency for a tube open at both ends is predicted by Euler's equation where:

$$w = (B \times L)^2 \times \sqrt{(E \times I / (\rho \times L^4))}$$

w - frequency radian per second - for frequency in cycles per second (Hz), $f = w / (2 \times \pi)$

E - modulus of elasticity

I - area moment of inertia = $\pi \times d^3 \times t / 8$ for a thin wall round tube

d - mean diameter

t - wall thickness

ρ = mass per unit length = Area x mass per unit volume = $\pi \times d \times t \times \text{density}$

L - length of tube

$$w = (B \times L)^2 \times (d / I^2) \times \sqrt{(1/8)} \times \sqrt{(E / \text{density})}$$

$(B \times L)^2$ - Constants based on the boundary conditions for a wind chime (Free-Free Beam)

$(B \times L)^2 = 22.373$ for the first natural frequency.

$(B \times L)^2 = 61.7$ for the second natural frequency.

$(B \times L)^2 = 121$ for the third natural frequency.

$(B \times L)^2 = 199.859$ for the fourth natural frequency.

To get the units correct you must multiply the values inside the square root by gravity (g).

$g = 386.4 \text{ in/sec}^2$ for these units.

For a given material then the frequency of a thin wall tube reduces to $f = \text{constant} \times d / I^2$

The formula reduces to:

Area Moment of Inertia = $\pi \times (OD^4 - ID^4) / 64$

Area = $\pi \times (OD^2 - ID^2) / 4$

$K = \sqrt{((\text{Elasticity} \times \text{Moment} \times \text{Gravity}) / (\text{Area} \times \text{Density}))}$

Chime Length (inches) = $\sqrt{(22.42 \times K / (2 \times \pi \times f))}$

If you're curious about the circular mode (not considered here) see this

<http://paws.kettering.edu/~drussell/Demos/radiation/radiation.html>

If you want additional math on the subject here is a paper by [Tom Irvine](#)

Appendix B - Music scale with overtones

A=440 Hz displaying the fundamental frequency and the first four overtones for a tube open at both ends

Note	A=440 Freq Hz	1st Overtone X 2.76	2nd Overtone X 5.40	3rd Overtone X 8.93	4th Overtone X 13.34	Note	Freq Hz	1st Overtone X 2.76	2nd Overtone X 5.40	3rd Overtone X 8.93	4th Overtone X 13.34
C0	16.40	45.18	88.56	146.45	218.78	G	392.00	1,079.96	2,116.80	3,500.56	5,229.28
C#/D ^b	17.30	47.30	93.42	154.49	230.78	G#/A ^b	415.30	1,144.15	2,242.62	3,708.63	5,540.10
D	18.40	50.69	99.36	164.31	245.46	A	440.01	1,212.23	2,376.05	3,929.29	5,869.73
D#/E ^b	19.40	53.45	104.76	173.24	258.80	A#/B ^b	466.20	1,284.38	2,517.48	4,163.17	6,219.11
E	20.60	56.75	111.24	183.96	274.80	B	493.91	1,360.72	2,667.11	4,410.62	6,588.76
F	21.80	60.06	117.72	194.67	290.81	C5	523.30	1,441.69	2,825.82	4,673.07	6,980.82
F#/G ^b	23.10	63.64	124.74	206.28	308.15	C#/D ^b	554.40	1,527.37	2,993.76	4,950.79	7,395.70
G	24.50	67.50	132.30	218.79	326.83	D	587.30	1,618.01	3,171.42	5,244.59	7,834.58
G#/A ^b	26.00	71.63	140.40	232.18	346.84	D#/E ^b	622.30	1,714.44	3,360.42	5,557.14	8,301.48
A	27.50	75.76	148.50	245.58	366.85	E	659.30	1,816.37	3,560.22	5,887.55	8,795.06
A#/B ^b	29.10	80.17	157.14	259.86	388.19	F	698.50	1,924.37	3,771.90	6,237.61	9,317.99
B	30.90	85.13	166.86	275.94	412.21	F#/G ^b	740.00	2,038.70	3,996.00	6,608.20	9,871.60
C1	32.70	90.09	176.58	292.01	436.22	G	784.00	2,159.92	4,233.60	7,001.12	10,458.56
C#/D ^b	34.60	95.32	186.84	308.98	461.56	G#/A ^b	830.60	2,288.30	4,485.24	7,417.26	11,080.20
D	36.70	101.11	198.18	327.73	489.58	A	880.00	2,424.40	4,752.00	7,858.40	11,739.20
D#/E ^b	38.90	107.17	210.06	347.38	518.93	A#/B ^b	932.30	2,568.49	5,034.42	8,325.44	12,436.88
E	41.21	113.53	222.53	368.01	549.74	B	987.80	2,721.39	5,334.12	8,821.05	13,177.25
F	43.70	120.39	235.98	390.24	582.96	C6	1,046.50	2,883.11	5,651.10	9,345.25	13,960.31
F#/G ^b	46.30	127.56	250.02	413.46	617.64	C#/D ^b	1,108.70	3,054.47	5,986.98	9,900.69	14,790.06
G	49.00	135.00	264.60	437.57	653.66	D	1,174.61	3,236.05	6,342.89	10,489.27	15,669.30
G#/A ^b	51.90	142.98	280.26	463.47	692.35	D#/E ^b	1,244.50	3,428.60	6,720.30	11,113.39	16,601.63
A	55.01	151.55	297.05	491.24	733.83	E	1,318.50	3,632.47	7,119.90	11,774.21	17,588.79
A#/B ^b	58.30	160.62	314.82	520.62	777.72	F	1,397.00	3,848.74	7,543.80	12,475.21	18,635.98
B	61.70	169.98	333.18	550.98	823.08	F#/G ^b	1,480.00	4,077.40	7,992.00	13,216.40	19,743.20
C2	65.40	180.18	353.16	584.02	872.44	G	1,568.00	4,319.84	8,467.20	14,002.24	20,917.12
C#/D ^b	69.30	190.92	374.22	618.85	924.46	G#/A ^b	1,661.20	4,576.61	8,970.48	14,834.52	22,160.41
D	73.41	202.24	396.41	655.55	979.29	A	1,760.00	4,848.80	9,504.00	15,716.80	23,478.40
D#/E ^b	77.80	214.34	420.12	694.75	1,037.85	A#/B ^b	1,864.60	5,136.97	10,068.84	16,650.88	24,873.76
E	82.40	227.01	444.96	735.83	1,099.22	B	1,975.50	5,442.50	10,667.70	17,641.22	26,353.17
F	87.30	240.51	471.42	779.59	1,164.58	C7	2,093.00	5,766.22	11,302.20	18,690.49	27,920.62
F#/G ^b	92.50	254.84	499.50	826.03	1,233.95	C#/D ^b	2,217.40	6,108.94	11,973.96	19,801.38	29,580.12
G	98.01	270.02	529.25	875.23	1,307.45	D	2,349.20	6,472.05	12,685.68	20,978.36	31,338.33
G#/A ^b	103.80	285.97	560.52	926.93	1,384.69	D#/E ^b	2,489.01	6,857.22	13,440.65	22,226.86	33,203.39
A	110.00	303.05	594.00	982.30	1,467.40	E	2,637.00	7,264.94	14,239.80	23,548.41	35,177.58
A#/B ^b	116.50	320.96	629.10	1,040.35	1,554.11	F	2,794.00	7,697.47	15,087.60	24,950.42	37,271.96
B	123.50	340.24	666.90	1,102.86	1,647.49	F#/G ^b	2,960.00	8,154.80	15,984.00	26,432.80	39,486.40
C3	130.81	360.38	706.37	1,168.13	1,745.01	G	3,136.00	8,639.68	16,934.40	28,004.48	41,834.24
C#/D ^b	138.60	381.84	748.44	1,237.70	1,848.92	G#/A ^b	3,322.41	9,153.24	17,941.01	29,669.12	44,320.95
D	146.80	404.43	792.72	1,310.92	1,958.31	A	3,520.00	9,697.60	19,008.00	31,433.60	46,956.80
D#/E ^b	155.60	428.68	840.24	1,389.51	2,075.70	A#/B ^b	3,729.20	10,273.95	20,137.68	33,301.76	49,747.53
E	164.80	454.02	889.92	1,471.66	2,198.43	B	3,951.00	10,885.01	21,335.40	35,282.43	52,706.34
F	174.61	481.05	942.89	1,559.27	2,329.30	C8	4,186.00	11,532.43	22,604.40	37,380.98	55,841.24
F#/G ^b	185.00	509.68	999.00	1,652.05	2,467.90	C#/D ^b	4,434.81	12,217.90	23,947.97	39,602.85	59,160.37
G	196.00	539.98	1,058.40	1,750.28	2,614.64	D	4,698.40	12,944.09	25,371.36	41,956.71	62,676.66
G#/A ^b	207.70	572.21	1,121.58	1,854.76	2,770.72	D#/E ^b	4,978.00	13,714.39	26,881.20	44,453.54	66,406.52
A	220.00	606.10	1,188.00	1,964.60	2,934.80	E	5,274.00	14,529.87	28,479.60	47,096.82	70,355.16
A#/B ^b	233.10	642.19	1,258.74	2,081.58	3,109.55	F	5,588.00	15,394.94	30,175.20	49,900.84	74,543.92
B	246.90	680.21	1,333.26	2,204.82	3,293.65	F#/G ^b	5,920.00	16,309.60	31,968.00	52,865.60	78,972.80
C4	261.60	720.71	1,412.64	2,336.09	3,489.74	G	6,272.00	17,279.36	33,868.80	56,008.96	83,668.48
C#/D ^b	277.20	763.69	1,496.88	2,475.40	3,697.85	G#/A ^b	6,644.80	18,306.42	35,881.92	59,338.06	88,641.63
D	293.70	809.14	1,585.98	2,622.74	3,917.96	A	7,040.00	19,395.20	38,016.00	62,867.20	93,913.60
D#/E ^b	311.10	857.08	1,679.94	2,778.12	4,150.07	A#/B ^b	7,458.40	20,547.89	40,275.36	66,603.51	99,495.06
E	329.61	908.08	1,779.89	2,943.42	4,397.00	B	7,902.01	21,770.04	42,670.85	70,564.95	105,412.81
F	349.30	962.32	1,886.22	3,119.25	4,659.66	C9	8,367.01	23,051.11	45,181.85	74,717.40	111,615.91
F#/G ^b	370.00	1,019.35	1,998.00	3,304.10	4,935.80						

Appendix C - Software resources [Read the Caution Here](#)



[Audacity](#)® Laptop freeware, open source, cross-platform software for recording and editing sounds. Good for fundamental and overtone frequency measurements.



[DL4YHF's Amateur Radio Software: Audio Spectrum Analyzer \(Spectrum Lab\)](#)
Laptop freeware good for fundamental and overtone frequency measurements.



[Tune Lab Pro version 4](#) Laptop freeware good for fundamental and overtone frequency measurements. At a cost, available for the iPhone, iPad and iPod Touch, Windows laptops, Windows Mobile Pocket PCs, Smartphones, and the Android.

Appendix D - Tubing and rod sources

Always try your local building supply store. In addition to visiting the hardware section in these stores investigate tubing used for closet hanging poles, shower curtain poles, chain link fence rails and post. Yard or garage sales can yield surprising results, look for a discarded metal swing set, tubular shelving, etc. With permission look for discarded materials on constructions sites.

Try your local metal recycler; they can yield very economical rod and tubing.

Tanks bells can be crafted from out-of-service compressed gas/air tanks, scuba diving tanks or fire extinguishers. A most likely source can be your local testing facility for each type of tank. Ask your local fire department, welding shop and scuba diving shop for their recommendation for a testing company. You may be required to provide a letter to the testing company stating that you will cut the tank in pieces and render it unable to hold compressed air or gas.

Online source for metal tubing and rods:

Always try your local building supply store. In addition to visiting the hardware section in these stores investigate tubing used for closet hanging poles, shower curtain poles, chain link fence rails and post. Yard or garage sales can yield surprising results, look for a discarded metal swing set, tubular shelving, etc. With permission look for discarded materials on constructions sites. Try your local metal recycler; they can yield very economical rod and tubing.

Online [Speedy Metals](#) accepts small quantity orders for tubes or rods.
(Aluminum, Brass, Cast Iron, Copper, Steel and Stainless)

[Titanium Joe](#) (Tubing) You can use either grade 2 being pure titanium, which is softer and less popular, or grade 9 (3AL-2.5V), which is the more popular high strength. The grade 9 numbers represent the percentage of Aluminum and Vanadium. The DIY Calculators work equally well for both grades.

Tank bells can be crafted from out-of-service compressed gas/air tanks, scuba diving tanks or fire extinguishers. A most likely source can be your local testing facility for each type of tank. Ask your local fire department, welding shop and scuba diving shop for their recommendation for a testing company. You may be required to provide a letter to the testing company stating that you will cut the tank in pieces and render it unable to hold compressed air or gas.

Appendix E - Standard Tubing Dimensions

What's the difference between a pipe and a tube? The way it's measured and the applications it's being used for. Pipes are passageways. Tubes are structural.

Aluminum and brass tubing tend to exactly follow their stated ID and OD dimensions while copper tubing does not. Wall thickness for copper pipe varies with the pipe schedule.

The four common schedules are named K (thick-walled), L (medium-walled), M (thin-wall), and DWV (drain/waste/vent - non-pressurized)

The printing on the pipe is color coded for identification;

K is Green, L is Blue, M is Red, and DWV is Yellow (drain/waste/vent, non-pressurized).

Both type **M** and type **L** can be found in home plumbing at Menards[®], Home Depot[®], Lowe's[®] and Ace Hardware[®].

Aluminum Tubing

Tubing Gauge	22	20	18	17	16	14	12
Wall Thickness	0.028	0.035	0.049	0.058	0.065	0.083	0.109

* These sizes are extruded; all other sizes are drawn tubes.

OD inches	ID inches	Wall inches	OD inches	ID inches	Wall inches	OD inches	ID inches	Wall inches
0.500	0.444	0.028	1.000	0.930	0.035	1.625	1.555	0.035
	0.430	0.035		0.902	0.049		1.509	0.058
	0.402	0.049		0.884	0.058	1.750	1.634	0.058
	0.384	0.058		0.870	0.065		1.584	0.083
	0.370	0.065		0.834	0.083	1.875	1.759	0.508
0.625	0.569	0.028	1.125	1.055	0.035	2.000	1.902	0.049
	0.555	0.035		1.009	0.058		1.870	0.065
	0.527	0.049	1.250	1.180	0.035		1.834	0.083
	0.509	0.058		1.152	0.049		1.750	*0.125
	0.495	0.065		1.134	0.058		1.500	*0.250
0.750	0.680	0.035		1.120	0.065	2.250	2.152	0.049
	0.652	0.049		1.084	0.083		2.120	0.065
	0.634	0.058	1.375	1.305	0.035		2.084	0.083
	0.620	0.065		1.259	0.058	2.500	2.370	0.065
	0.584	0.083	1.500	1.430	0.035		2.334	0.083
0.875	0.805	0.035		1.402	0.049		2.250	*0.125
	0.777	0.049		1.384	0.058		2.000	*0.250
	0.759	0.058		1.370	0.065	3.000	2.870	0.065
	0.745	0.065		1.334	0.083		2.750	*0.125
				1.250	*0.125		2.500	*0.250
				1.000	*0.250			

Brass tubing

Available sizes for Tube Brass

1/2" OD {A} x 0.436" ID {B} x .032" Wall
 1/2" OD {A} x 0.370" ID {B} x .065" Wall
 5/8" OD {A} x 0.561" ID {B} x .032" Wall
 5/8" OD {A} x 0.495" ID {B} x .065" Wall
 3/4" OD {A} x 0.686" ID {B} x .032" Wall
 3/4" OD {A} x 0.620" ID {B} x .065" Wall
 1" OD {A} x 0.870" ID {B} x .065" Wall
 1-1/4" OD {A} x 1.120" ID {B} x .065" Wall
 1-1/2" OD {A} x 1.370" ID {B} x .065" Wall
 1-1/2" OD {A} x 1.250" ID {B} x .125" Wall
 1-5/8" OD {A} x 1.375" ID {B} x .125" Wall
 1-3/4" OD {A} x 1.620" ID {B} x .065" Wall
 2" OD {A} x 1.870" ID {B} x .065" Wall
 2-1/4" OD {A} x 2.120" ID {B} x .065" Wall

Available sizes for BRASS TUBE

0.5" OD x 0.03" WALL x 0.44" ID
 0.5" OD x 0.042" WALL x 0.416" ID
 0.5" OD x 0.065" WALL x 0.37" ID
 0.625" OD x 0.029" WALL x 0.567" ID
 0.625" OD x 0.065" WALL x 0.495" ID
 0.75" OD x 0.029" WALL x 0.692" ID
 0.75" OD x 0.04" WALL x 0.67" ID
 0.75" OD x 0.065" WALL x 0.62" ID C330 TUBE
 0.75" OD x 0.12" WALL x 0.51" ID
 0.875" OD x 0.03" WALL x 0.815" ID
 0.875" OD x 0.065" WALL x 0.745" ID
 1" OD x 0.03" WALL x 0.94" ID
 1" OD x 0.065" WALL x 0.87" ID
 1.25" OD x 0.04" WALL x 1.17" ID
 1.25" OD x 0.065" WALL x 1.12" ID
 1.5" OD x 0.04" WALL x 1.42" ID
 1.5" OD x 0.065" WALL x 1.37" ID
 1.75" OD x 0.065" WALL x 1.62" ID
 1.75" OD x 0.12" WALL x 1.51" ID
 2" OD x 0.049" WALL x 1.902" ID
 2" OD x 0.065" WALL x 1.87" ID
 2" OD x 0.109" WALL x 1.782" ID
 2" OD x 0.12" WALL x 1.76" ID
 2.5" OD x 0.065" WALL x 2.37" ID
 3" OD x 0.049" WALL x 2.902" ID
 3" OD x 0.065" WALL x 2.87" ID
 4" OD x 0.065" WALL x 3.87" ID C330 TUBE



Copper tubing

Wall thickness for copper pipe varies with the pipe schedule.
The four common schedules are named K (thick-walled), L (medium-walled), M (thin-wall), and DWV (drain/waste/vent - non-pressurized).

The printing on the pipe is color coded for identification;

K is Green, L is Blue, M is Red, and DWV is Yellow (drain/waste/vent, non-pressurized).

Both type **M** and type **L** can be found in home plumbing at Menards®, Home Depot®, Lowe's® and Ace Hardware®.

Nominal Pipe Size	Actual O.D.	I.D.				Wall Thickness			
		K	L	M	DWV	K	L	M	DWV
½ inch	0.625	0.527	0.545	0.569	-	0.049	0.040	0.028	-
5/8 inch	0.750	0.652	0.666	-	-	0.049	0.042	-	-
¾ inch	0.875	0.745	0.785	0.811	-	0.065	0.045	0.032	-
1 inch	1.125	0.995	1.025	1.055	-	0.065	0.050	0.035	-
1 ¼ inch	1.375	1.245	1.265	1.291	1.295	0.065	0.055	0.042	0.04
1 ½ inch	1.625	1.481	1.505	1.527	1.541	0.072	0.060	0.049	0.042
2 inch	2.125	1.959	1.985	2.009	2.041	0.083	0.070	0.058	0.042
2 ½ inch	2.625	2.435	2.465	2.495	-	0.095	0.080	0.065	-
3 inch	3.125	2.907	2.945	2.981	3.03	0.109	0.090	0.072	0.045
3 ½'	3.625	3.385	3.425	3.259		0.120	0.100	0.083	
4	4.125	3.857	3.897	3.707		0.134	0.114	0.095	
5	5.125	4.805	4.875	4.657		0.160	0.125	0.109	
6	6.125	5.741	5.845	5.601		0.192	0.140	0.122	

Electrical metallic tubing (EMT) aka thin-wall steel conduit

EMT (inches)	Actual (OD) (inches)	(ID) (inches)	Wall Thickness	Gauge
3/8"	.577	.493	.042	19
½"	.706	.622	.042	19
¾"	.922	.824	.049	18
1	1.163	1.049	.057	17
1 ¼"	1.510	1.380	.065	16
1 ½"	1.740	1.610	.065	16
2	2.197	2.067	.065	16
2 ½"	2.875	2.731	.072	15
3	3.500	3.356	.072	15
3 ½"	4.000	3.834	.083	14
4	4.500	4.334	.083	14

Iron pipe

Pipe is specified by a nominal dimension which bears little or no resemblance to the actual dimensions of the pipe.

Wrought iron pipe (Schedule 40) is used for water supply in older houses and is available in either black or galvanized. Joints are made by threading pipe into cast iron fittings.			
Nominal Pipe Size inches	O.D.	I.D.	Wall Thickness
1	1.315	1.049	0.133
1.250	1.660	1.380	0.140
1.500	1.900	1.610	0.145
2	2.375	2.067	0.154
2.500	2.875	2.468	0.204

Cast iron pipe is typically used for sewer lines and municipal water. Available in eight classes, A through H, rated by pressure in increments of 100 feet of head.						
Nominal Pipe Size inches	Class A 100 Foot Head 43 psi			Class B 200 Foot Head 86 psi		
	O.D.	I.D.	Wall Thickness	O.D.	I.D.	Wall Thickness
3	3.800	3.020	0.390	3.960	3.120	0.420
4	4.800	3.960	0.420	5.000	4.100	0.450
6	6.900	6.020	0.440	7.100	6.140	0.480
8	9.050	8.130	0.460	9.050	8.030	0.510
10	11.100	10.100	0.500	11.100	9.960	0.570

Appendix F - Internet Resources/Links

Chuck's Chimes another engineer, Chuck, has an excellent website for chime calculations and information for building a special set of chimes where the chime tube is resonant for both the air column resonance and the metal wall resonance. www.sites.google.com/site/chuckchimes/home

The Sound of Bells This site has pages for bell sounds and tuning in addition to free software that lets you listen to the effects of overtones and allows you to tune your bell or chime using a sound card and microphone. www.hibberts.co.uk/index.htm

The Acoustics of Bells, See chapter 5: The Acoustics of Bells is a nice introduction to bell physics. www.msu.edu/~carillon/batmbook/index.htm

Pitch Perception Psychoacoustics of pitch perception. www.mmk.ei.tum.de/persons/ter/top/pitch.html

The strike note of bells www.mmk.ei.tum.de/persons/ter/top/strikenote.html

Appendix G Credits

Thank you to the many website visitors for your ideas, creativity and suggestions included in this document.

Appendix H: Design styles



In-line arrangement with a conceal and carry striker.



Horizontally mounted chimes with individual strikers.



No requirement for the support disk to be horizontal.



Rod chimes use a solid metal ball as the striker. Closely spaced large diameter chimes can work well without a wind sail

Appendix J: Table for an audible fundamental or lack of and its overtones for a chime.

The blue shaded area of the chart represents a frequency range from 300 Hz to 3,000 Hz. This demonstrates a range for audible fundamental frequencies and their overtones beginning at about C2 and moving upward to about C4. Note that the fundamental is mostly inaudible below about C4. The more overtones present the more melodious the strike note. The range of 300 Hz to 3000 Hz was selected as an example for a possible listening range and does not represent the complete audible range.

Octave	Musical Note	Frequency Hz	1st Overtone X 2.76	2nd Overtone X 5.40	3rd Overtone X 8.93	4th Overtone X 13.34	5th Overtone X 18.64	6th Overtone X 31.87
1	C		90	177	292	436	610	1,042
	C#		95	187	309	462	645	1,103
	D	36.70	101	198	328	490	684	1,170
	Eb	38.90	107	210	347	519	725	1,240
	E	41.21	114	223	368	550	768	1,313
	F	43.70	120	236	390	583	815	1,393
	F#	46.30	128	250	413	618	863	1,476
	G	49.00	135	265	438	654	913	1,562
	Ab	51.90	143	280	463	692	967	1,654
	A	55.01	152	297	491	734	1,025	1,753
	Bb	58.30	161	315	521	778	1,087	1,858
2	B	61.70	170	333	551	823	1,150	1,966
	C	65.40	180	353	584	872	1,219	2,084
	C#	69.30	191	374	619	924	1,292	2,209
	D	73.41	202	396	656	979	1,368	2,340
	Eb	77.80	214	420	695	1,038	1,450	2,479
	E	82.40	227	445	736	1,099	1,536	2,626
	F	87.30	241	471	780	1,165	1,627	2,782
	F#	92.50	255	500	826	1,234	1,724	2,948
	G	98.01	270	529	875	1,307	1,827	3,124
	Ab	103.80	286	561	927	1,385	1,935	3,308
	A	110.00	303	594	982	1,467	2,050	3,506
3	Bb	116.50	321	629	1,040	1,554	2,172	3,713
	B	123.50	340	667	1,103	1,647	2,302	3,936
	C	130.81	360	706	1,168	1,745	2,438	4,169
	C#	138.60	382	748	1,238	1,849	2,584	4,417
	D	146.80	404	793	1,311	1,958	2,736	4,679
	Eb	155.60	429	840	1,390	2,076	2,900	4,959
	E	164.80	454	890	1,472	2,198	3,072	5,252
	F	174.61	481	943	1,559	2,329	3,255	5,565
	F#	185.00	510	999	1,652	2,468	3,448	5,896
	G	196.00	540	1,058	1,750	2,615	3,653	6,247
	Ab	207.70	572	1,122	1,855	2,771	3,872	6,619
4	A	220.00	606	1,188	1,965	2,935	4,101	7,011
	Bb	233.10	642	1,259	2,082	3,110	4,345	7,429
	B	246.90	680	1,333	2,205	3,294	4,602	7,869
	C	261.60	721	1,413	2,336	3,490	4,876	8,337
	C#	277.20	764	1,497	2,475	3,698	5,167	8,834
	D	293.70	809	1,586	2,623	3,918	5,475	9,360
	Eb	311.10	857	1,680	2,778	4,150	5,799	9,915
	E	329.61	908	1,780	2,943	4,397	6,144	10,505
	F	349.30	962	1,886	3,119	4,660	6,511	11,132
	F#	370.00	1,019	1,998	3,304	4,936	6,897	11,792
	G	392.00	1,080	2,117	3,501	5,229	7,307	12,493
Ab	415.30	1,144	2,243	3,709	5,540	7,741	13,236	

	A	440.01	1,212	2,376	3,929	5,870	8,202	14,023
	Bb	466.20	1,284	2,517	4,163	6,219	8,690	14,858
	B	493.91	1,361	2,667	4,411	6,589	9,206	15,741
5	C	523.30	1,442	2,826	4,673	6,981	9,754	16,678
	C#	554.40	1,527	2,994	4,951	7,396	10,334	17,669
	D	587.30	1,618	3,171	5,245	7,835	10,947	18,717
	Eb	622.30	1,714	3,360	5,557	8,301	11,600	19,833
	E	659.30	1,816	3,560	5,888	8,795	12,289	21,012
	F	698.50	1,924	3,772	6,238	9,318	13,020	22,261
	F#	740.00	2,039	3,996	6,608	9,872	13,794	23,584
	G	784.00	2,160	4,234	7,001	10,459	14,614	24,986
	Ab	830.60	2,288	4,485	7,417	11,080	15,482	26,471
	A	880.00	2,424	4,752	7,858	11,739	16,403	28,046
	Bb	932.30	2,568	5,034	8,325	12,437	17,378	29,712
	B	987.80	2,721	5,334	8,821	13,177	18,413	31,481
6	C	1,046.50	2,883	5,651	9,345	13,960	19,507	33,352
	C#	1,108.70	3,054	5,987	9,901	14,790	20,666	35,334
	D	1,174.61	3,236	6,343	10,489	15,669	21,895	37,435
	Eb	1,244.50	3,429	6,720	11,113	16,602	23,197	39,662
	E	1,318.50	3,632	7,120	11,774	17,589	24,577	42,021
	F	1,397.00	3,849	7,544	12,475	18,636	26,040	44,522
	F#	1,480.00	4,077	7,992	13,216	19,743	27,587	47,168
	G	1,568.00	4,320	8,467	14,002	20,917	29,228	49,972
	Ab	1,661.20	4,577	8,970	14,835	22,160	30,965	52,942
	A	1,760.00	4,849	9,504	15,717	23,478	32,806	56,091
	Bb	1,864.60	5,137	10,069	16,651	24,874	34,756	59,425
	B	1,975.50	5,443	10,668	17,641	26,353	36,823	62,959
7	C	2,093.00	5,766	11,302	18,690	27,921	39,014	66,704
	C#	2,217.40	6,109	11,974	19,801	29,580	41,332	70,669
	D	2,349.20	6,472	12,686	20,978	31,338	43,789	74,869
	Eb	2,489.01	6,857	13,441	22,227	33,203	46,395	79,325
	E	2,637.00	7,265	14,240	23,548	35,178	49,154	84,041
	F	2,794.00	7,697	15,088	24,950	37,272	52,080	89,045
	F#	2,960.00	8,155	15,984	26,433	39,486	55,174	94,335
	G	3,136.00	8,640	16,934	28,004	41,834	58,455	99,944
	Ab	3,322.41	9,153	17,941	29,669	44,321	61,930	105,885
	A	3,520.00	9,698	19,008	31,434	46,957	65,613	112,182
	Bb	3,729.20	10,274	20,138	33,302	49,748	69,512	118,850
	B	3,951.00	10,885	21,335	35,282	52,706	73,647	125,918
8	C	4,186.00	11,532	22,604	37,381	55,841	78,027	133,408
	C#	4,434.81	12,218	23,948	39,603	59,160	82,665	141,337
	D	4,698.40	12,944	25,371	41,957	62,677	87,578	149,738
	Eb	4,978.00	13,714	26,881	44,454	66,407	92,790	158,649
	E	5,274.00	14,530	28,480	47,097	70,355	98,307	168,082
	F	5,588.00	15,395	30,175	49,901	74,544	104,160	178,090
	F#	5,920.00	16,310	31,968	52,866	78,973	110,349	188,670
	G	6,272.00	17,279	33,869	56,009	83,668	116,910	199,889
	Ab	6,644.80	18,306	35,882	59,338	88,642	123,859	211,770
	A	7,040.00	19,395	38,016	62,867	93,914	131,226	224,365
	Bb	7,458.40	20,548	40,275	66,604	99,495	139,025	237,699
	B	7,902.01	21,770	42,671	70,565	105,413	147,293	251,837

Originally published 10/01/2012